

User Manual

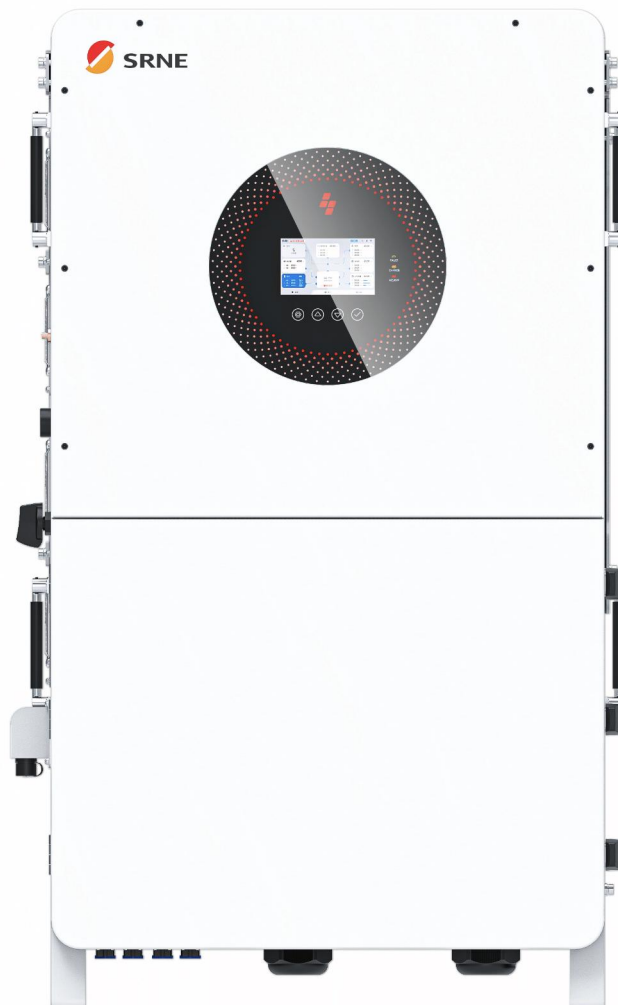

Solar Hybrid Inverter

IESP500SH3 | IESP550SH3 | IESP600SH3



READ THE INSTRUCTIONS COMPLETELY BEFORE OPERATING THE EQUIPMENT

[Disregarding these instructions could result in permanent damage to the unit]

Due to product iteration and upgrade requirements, the equipment specifications, parameters and functional configurations are subject to timely updates and adjustments. The latest version of the user manual can be obtained via the official website:

<https://www.szshuori.com>. We have made every effort to ensure the completeness and accuracy of the content in this document; however, SRNE reserves the right to modify product and document content without prior notice.

Users must strictly follow the provisions of this manual throughout the entire process of equipment installation, operation and maintenance. SRNE shall not be liable for any consequences arising from failure to operate in accordance with the requirements specified in this manual. Meanwhile, SRNE shall only be responsible for the inverter equipment supplied herewith, and shall not assume joint and several liability for any associated upstream or downstream systems related to the equipment.

The Company shall not be liable for damage caused by :

- ① Damage caused by improper use or use in a wrong location.
- ② PV modules with an open-circuit voltage exceeding the maximum permissible voltage.
- ③ Damage caused by the operating temperature exceeding the restricted operating temperature range.
- ④ Dismantling and repair of the inverter by unauthorised persons.
- ⑤ Damage caused by force majeure: damage during transport or handling of the inverter.

This manual applies exclusively to the IESP Series:

IESP500SH3

IESP550SH3

IESP600SH3



Please scan the QR code
to download the user manual

Contents

1. Safety	6
1.1 How to Use This Manual	6
1.2 Symbols in This Manual	6
1.3 Safety Instruction	6
2. Product Introduction	7
2.1 Product Description	7
2.2 Product Features	7
2.3 System Connection Diagram	8
2.4 Product Overview	9
2.5 Product Size	10
3. Installation	11
3.1 Installation List	11
3.2 Mounting Instructions	12
3.2.1 Installation Location Selection	12
3.2.2 Mounting the Inverter	13
3.2.3 Removing the Terminal Protection Cover	14
4. Connection	15
4.1 Single-Phase or Three-Phase Mode	15
4.2 Cable & Circuit Breaker Selection	15
4.3 Grid Input Connection	17
4.4 Load Output Connection	17
4.5 Generator Input Connection	18
4.6 Battery Connection	18
4.7 PV Connection	20
4.8 Dry Contact Connection	21
4.9 Grounding Connection	21
4.10 Inverter Start	22
4.11 Parallel Connection	22
4.11.1 Introduction to Parallel Connection	22
4.11.2 Precautions for Connecting Parallel Connection Cables	22
4.11.3 Schematic of Three-Phase Parallel Operation	23
5. Operation	26
5.1 Operation and Display Panel	26
5.2 Setting Parameters	30
5.2.1 Basic Setup	32
5.2.2 Work Mode Setup	32
5.2.3 Battery Setup	34
5.2.4 Grid Connection Setup	37
5.2.5 Advanced Setup	39
5.2.6 WiFi Setup	42
5.2.7 Firmware Upgrade via USB Drive	43
5.3 Time-slot Charging/Discharging Function	44
6. Communication	45
6.1 Product Overview	45
6.2 USB-1 Communication Port	46
6.3 WiFi Communication Function	46
6.4 485/Meter Port	47
6.5 485/EMS Port	47
6.6 CAN/485/BMS1/BMS2 Communication Ports	47
6.7 USB-2 Display Port	47

6.8 DRM(Only Australia)	48
6.9 External CT Prot	48
6.10 Dry Contact Function	49
6.11 DIP Switch Configuration	50
6.12 Remote Monitoring	50
6.12.1 Download App	50
6.12.2 Stick Logger Installation	50
6.12.3 SOLARMAN Smart APP Operation	51
6.12.4 Plant Detail	54
6.12.5 Abnormal State Processing	55
7. Working Modes	58
8. Fault and Remedy	60
8.1 Fault Codes	60
8.2 Troubleshooting	62
9. Protection and Maintenance	63
9.1 Protection Features	63
9.2 Maintenance	64
9.3 Storage	64
10. Datasheet	65

1. Safety





1.1 How to Use This Manual

This manual contains important information, guidelines, operation and maintenance for the following products :

IESP Series: 500SH3, 550SH3, 600SH3.

Read the manual and other related documents before performing any operation on the inverter. Documents must be stored carefully and be available at all times.

1.2 Symbols in This Manual

 DANGER	DANGER: Indicates a hazardous situation which, if not avoided, will result in death or serious injury.
 WARNING	WARNING: Indicates a hazardous situation which, if not avoided, could result in death or serious injury.
 CAUTION	CAUTION: Indicates a hazardous situation which, if not avoided, may result in minor or moderate injury.
 NOTICE	NOTICE: Provides tips or cues regarding product operation.

1.3 Safety Instruction

WARNING: This chapter contains important safety and operating instructions. Read and keep this manual for future reference.

- Be sure to comply the local requirements and regulation to install this inverter.
- Beware of high voltage. Please turn off the switch of each power sources before and during the installation to avoid electric shock.
- For optimum operation of this inverter, please follow required specification to select appropriate cable size and necessary protective device.
- Do not connect or disconnect any connections when the inverter is working.
- Do not open the terminal cover when the inverter working.
- Make sure the inverter is well grounding.
- Never cause AC output and DC input short circuited.
- Do not disassembly this unit, for all repair and maintenance, please take it to the professional service center.
- Never charge a frozen battery.

2. Product Introduction

2.1 Product Description

The IESP SH3 series is a new type of photovoltaic energy storage inverter that integrates PV power generation, grid charging, and energy storage, and supports AC sine wave output. It is highly compatible with various application scenarios, including residential energy storage systems.

It adopts DSP control and achieves high response speed, reliability, and compliance with an industrial standard through an advanced control algorithm. It provides users with a reliable and efficient energy conversion solution.

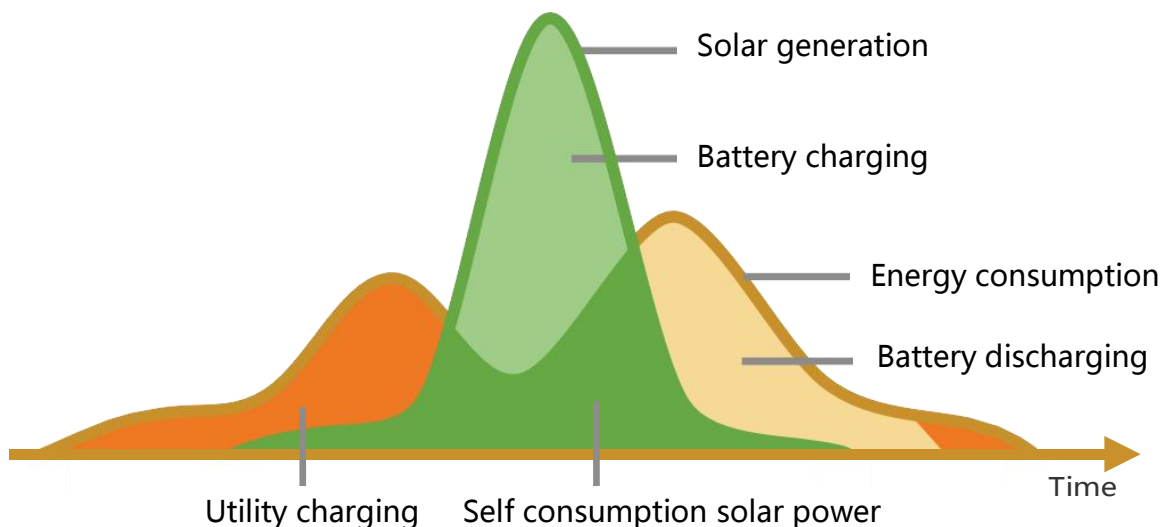

2.2 Product Features

- Supports two independent battery inputs with 80A + 80A, flexibly compatible with mainstream battery modules of 100-314 AH on the market.
- Supports smart load function with intelligent load connection control based on battery status.
- Supports AC coupling function for flexible integration into existing PV systems.
- With a dual activation function when the li-ion battery is dormant; either grid/ photovoltaic power supply access can trigger the activation of the li-ion battery.
- Supports three-phase pure sine wave output.
- 100% three-phase unbalanced output.
- Supports phase voltage adjustment within the AC range of 200V, 208V, 220V, 230V and 240V.
- Integrates 4 MPPT trackers, 8 PV string inputs, a maximum string current of 20A, and is compatible with 182mm and 210mm PV modules.
- Supports multiple charging modes: Solar-only charging, grid & PV hybrid charging, diesel generator charging, etc.

- With the time-slot charging and discharging setting function, helping users fully utilize peak and valley electricity prices to reduce electricity costs.
- Energy saving mode function to reduce no-load energy losses.
- With two output modes of utility bypass and inverter output, with uninterrupted power supply function.
- LCD large screen dynamic flow diagram design, easy to understand the system data and operation status.
- Multifunctional protection logic, including short circuit, overcurrent, overvoltage, undervoltage, overload, overtemperature and other protections.
- Support CAN, USB, and RS485 communication.

2.3 System Connection Diagram

The following figure illustrates the product's system application scenario. A complete system consists of the following components:

- **PV Modules:** Converts light energy into DC energy, which can be used to charge the battery via an inverter or directly inverted into AC power to supply the load.
- **Grid:** Connected to the grid AC input, supplying power to loads while charging batteries. The system can operate off-grid when batteries and PV modules power the loads.
- **Battery:** The role of the battery is to ensure the normal power supply of the system loads in case of insufficient photovoltaic and no utility power.
- **Home Load:** Connects to a variety of home and office loads including refrigerators, lamps, TVs, fans, air conditioners and other AC loads.
- **Generator/Smart Load/Micro-inverter Input:** When connected to an AC generator, supplies power to loads and charges batteries simultaneously. Without generator connection, this interface can be configured as a smart load output to power loads. When connected to micro-inverters, it supplies power to loads and charges batteries concurrently.
- **Inverter:** It is the energy conversion device of the whole system.

Note: The actual application scenario determines the specific system cabling.

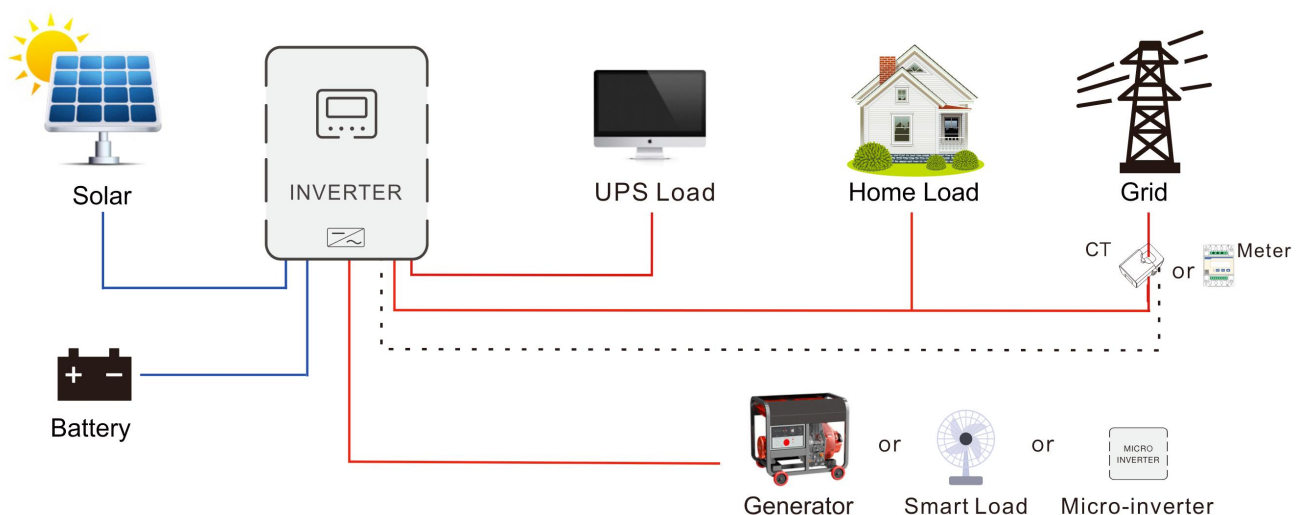

2.4 Product Overview

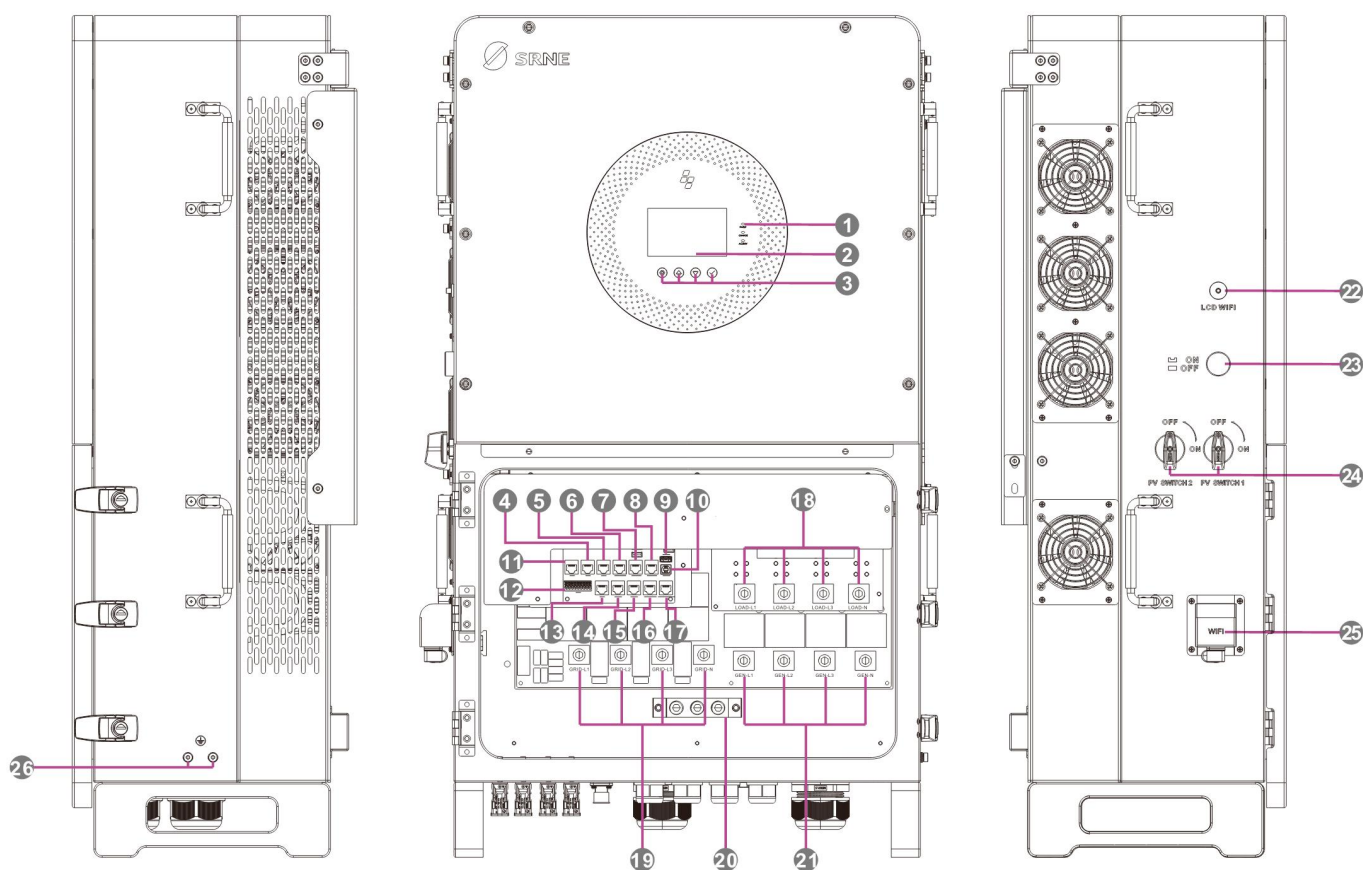

1	LED Indicators	2	LCD Screen	3	Operation Buttons
4	Micro-inverter CT2	5	DRM	6	485/Meter Port
7	485/WiFi Port	8	485/EMS Port	9	Display Prot USB-2
10	Communication Prot USB-1	11	Anti-backflow CT1 Prot	12	Dry Contact Interface
13	CAN2 Communication Port	14	Parallel Operation Port -B	15	Parallel Operation Port -A
16	CAN2/485/BMS2 Communication Port	17	CAN3/485/BMS1 Communication Port	18	Load Ports (L1+L2+L3+N)
19	Grid Ports (L1+L2+L3+N)	20	Electrical Grounding	21	Generator Ports (L1+L2+L3+N)
22	Display WiFi Interface	23	Operation Switch	24	PV Input Switch
25	WiFi Module	26	Casing Grounding		



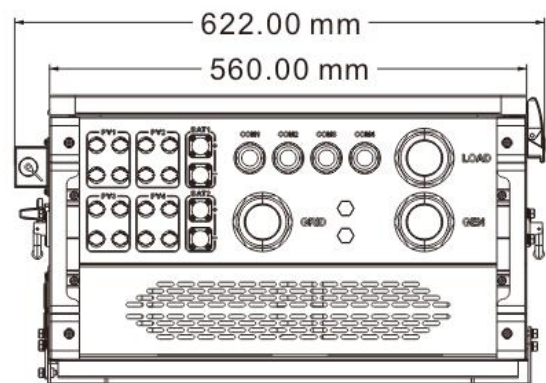
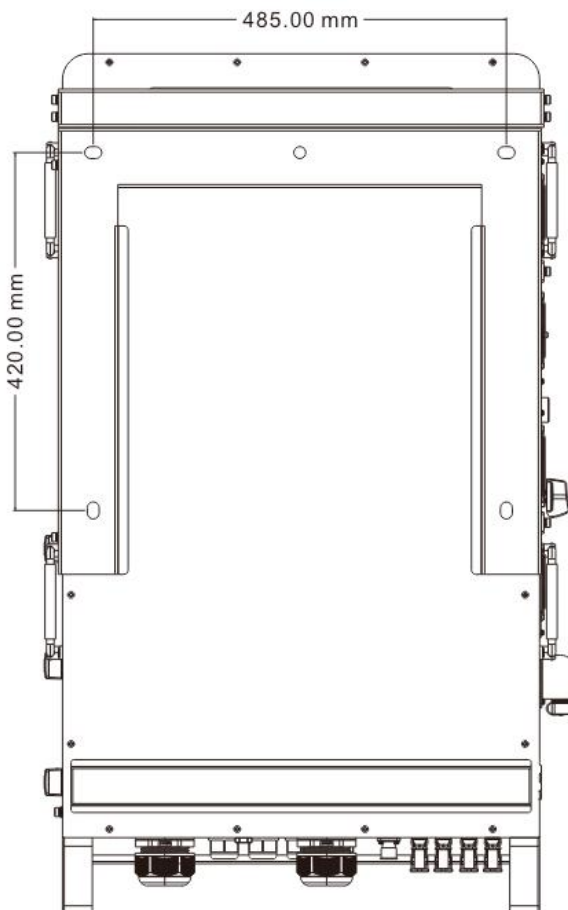
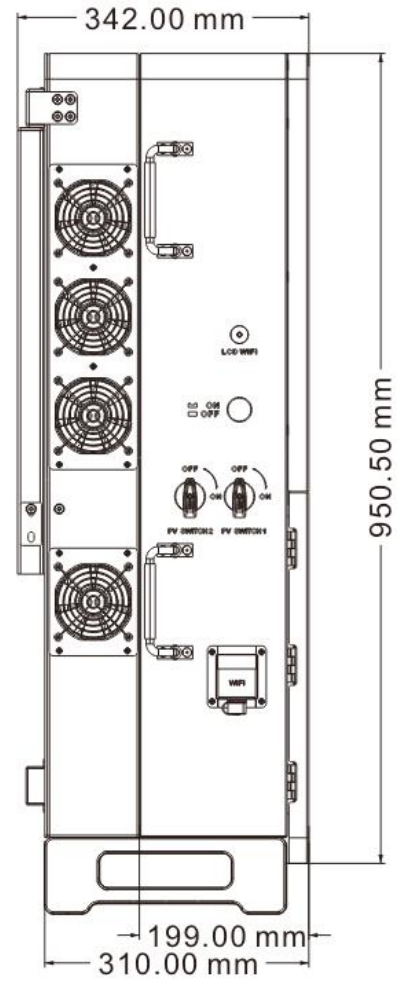
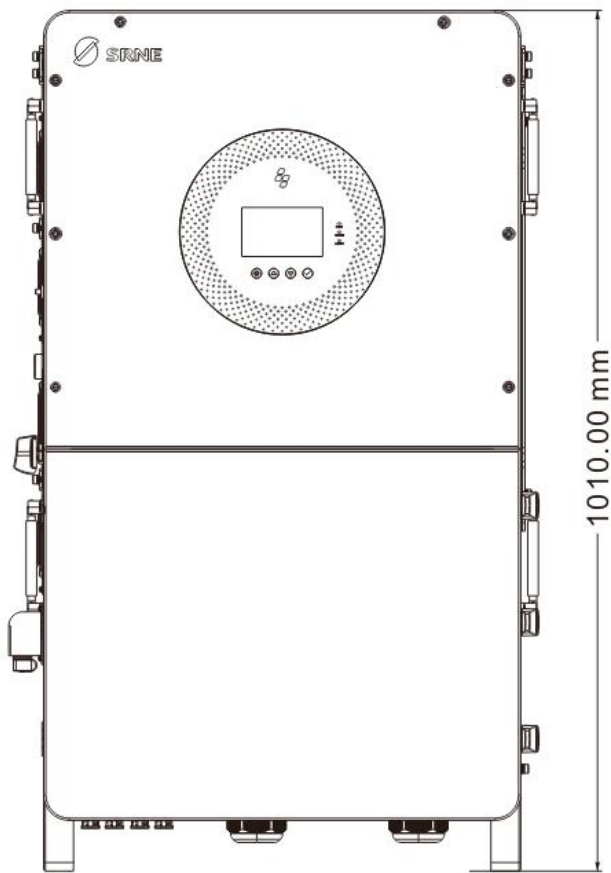





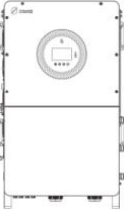

2.5 Product Size

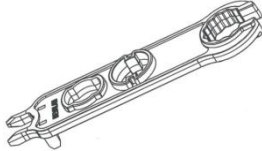

3. Installation

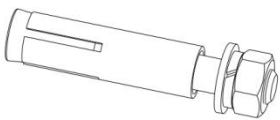
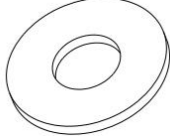
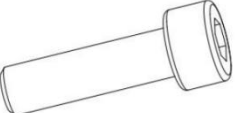
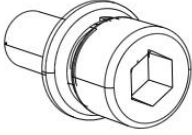
3.1 Installation List

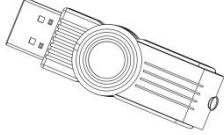
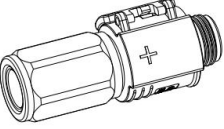
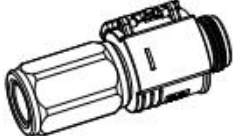
Please check the equipment before installation. Make sure that there is no damage to the packaging. You should have received the following items in the package:

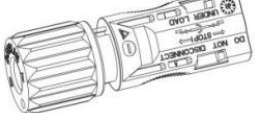
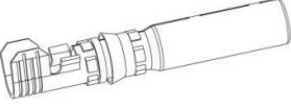
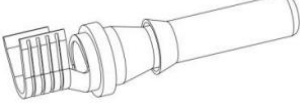
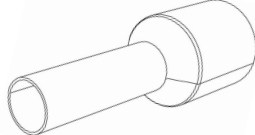
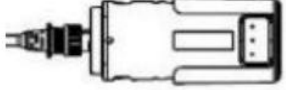
 <p>Hybrid inverter x 1pcs</p>	 <p>Wall mount bracket x 1pcs</p>	 <p>MC4 unlocking tool x 1pcs</p>	 <p>Hex wrench L-shaped_5mm x 1pcs</p>
 <p>Hex wrench T-shaped_8mm x 1pcs</p>	 <p>Suspension ring M8*15mm x 1pcs</p>	 <p>Expansion screws M8*60mm x 2pcs</p>	 <p>M8 flat washer x 5pcs</p>
 <p>Hex socket head cap screws M6*18mm x 2pcs</p>	 <p>Hex socket head triple-combination screws M6*16mm x 4pcs</p>	 <p>Keys x 6pcs</p>	 <p>USB flash drive x 1pcs</p>
 <p>Battery+ terminal x 2pcs</p>	 <p>Battery- terminal x 2pcs</p>	 <p>PV+ terminal x 8pcs</p>	 <p>PV- terminal x 8pcs</p>
 <p>PV+ input metal core x 8pcs</p>	 <p>PV- input metal core x 8pcs</p>	 <p>Tubular terminal block E50-20 x 15pcs</p>	 <p>WiFi module x 1pcs</p>

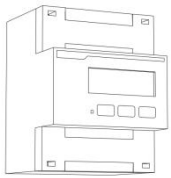

Three-phase meter
(Optional)
x 1pcs

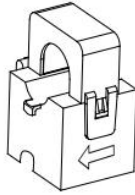

CT
x 3pcs



User manual
x 1pcs



Quality certificate /
Outgoing inspection
report
x 1pcs / x 1pcs

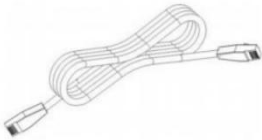

Parallel connection
cable
x 1pcs

3.2 Mounting Instructions

3.2.1 Installation Location Selection

The IESP SH3 series can be used outdoors (protection class IP65). Please consider the followings before selecting the location:

- Choose the solid wall to install the inverter.
- Mount the inverter at eye level.
- Adequate heat dissipation space must be provided for the inverter. (specific requirements: the heat dissipation distance above and below the inverter should be $\geq 500\text{mm}$, and the distance on both left and right sides should be $\geq 500\text{mm}$).
- The ambient temperature should be between $-40^{\circ}\text{C} \sim 60^{\circ}\text{C}$ ($-40^{\circ}\text{F} \sim 140^{\circ}\text{F}$) to ensure optimal operation.

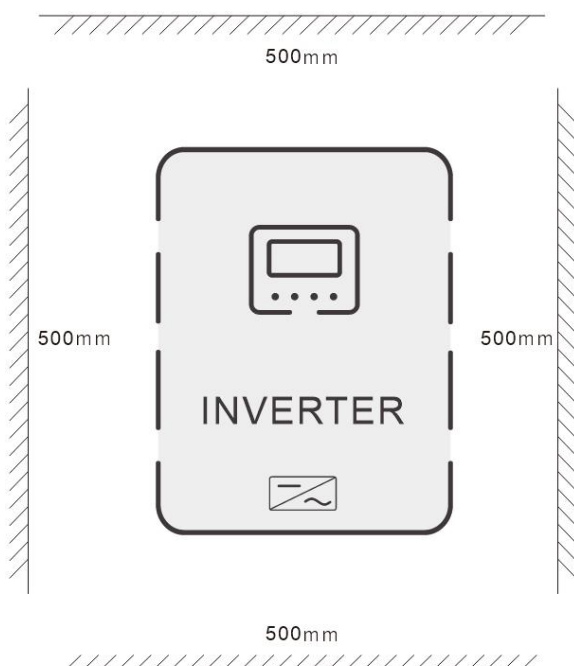

DANGER

- Do not install the inverter where highly flammable materials are near by.
- Do not install the inverter in potential explosive areas.
- Do not install the inverter with lead-acid batteries in a confined space.

CAUTION

- Do not install the inverter in direct sunlight.
- Do not install or use the inverter in a humid environment.

3.2.2 Mounting the Inverter

- **Step 1:** Determine the positions for drilling holes, ensure the position of holes are level, then mark them with a marker pen, use the hammer drill to drill holes on the wall. Keep the hammer drill perpendicular to the wall, do not shake when drilling, so as not to damage the wall. If the error of the hole is too big, you need to reposition.
- **Step 2:** Insert M8*60 expansion bolt vertically into the hole and pay attention to the insertion depth of the expanding bolt (should be deep enough).
- **Step 3:** Align the wall hanger with the position of holes, fix the wall hanger on the wall by tightening the expansion bolt with nuts.
- **Step 4:** Align the mounting holes and attach the inverter to the wall bracket, securing it in place with safety screws.

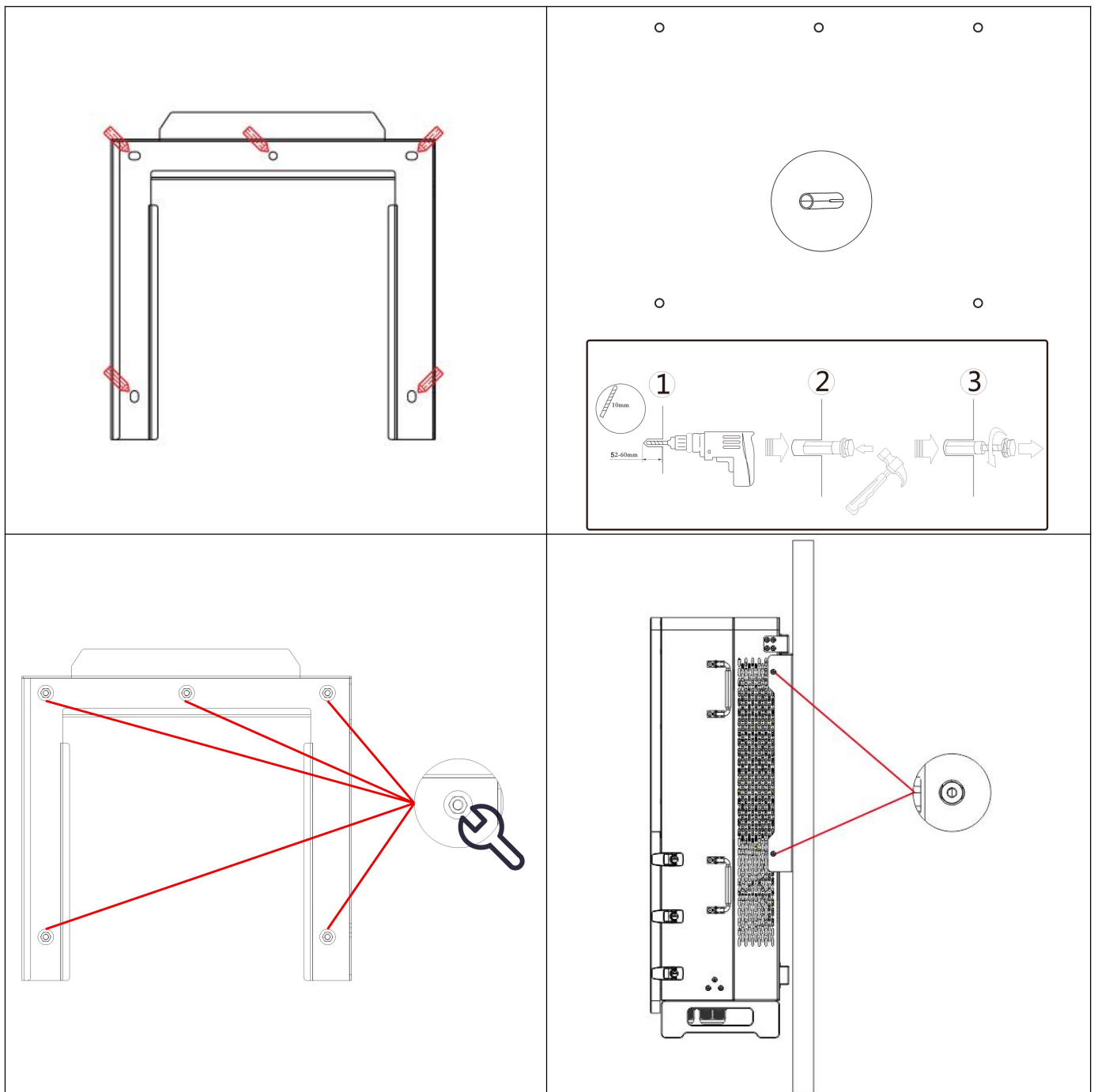

3.2.3 Removing the Terminal Protection Cover

Use the key to unlock the tower buckle lock, and the protective cover can be opened.

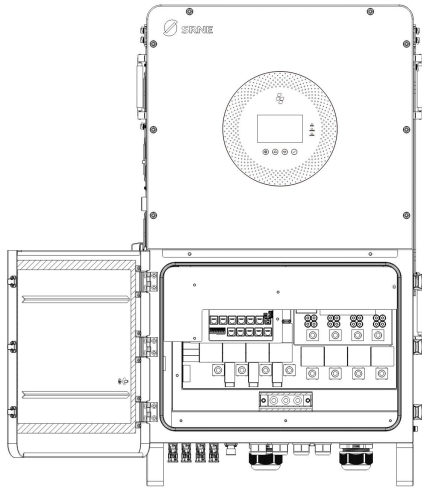

Wiring. (Note: The wire must be inserted into the corresponding connector before crimping the terminal.)

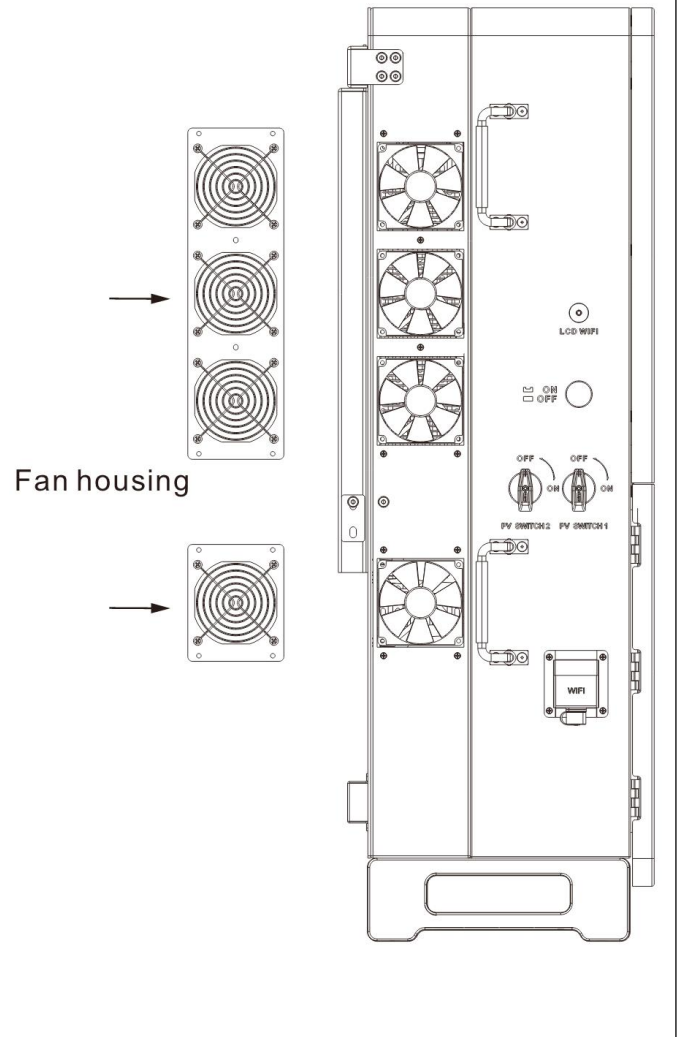
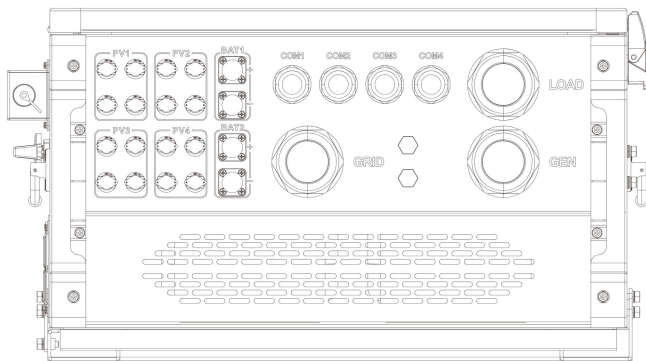

NOTICE

When using the device in areas with poor air quality, the dust screen is easily blocked by air particles. Please disassemble and clean the dust screen periodically to avoid affecting the internal air flow rate of the inverter, which may trigger an over-temperature protection fault (19/20 fault) affecting the use of the power supply and the service life of the inverter.

4. Connection

4.1 Single-Phase or Three-Phase Mode

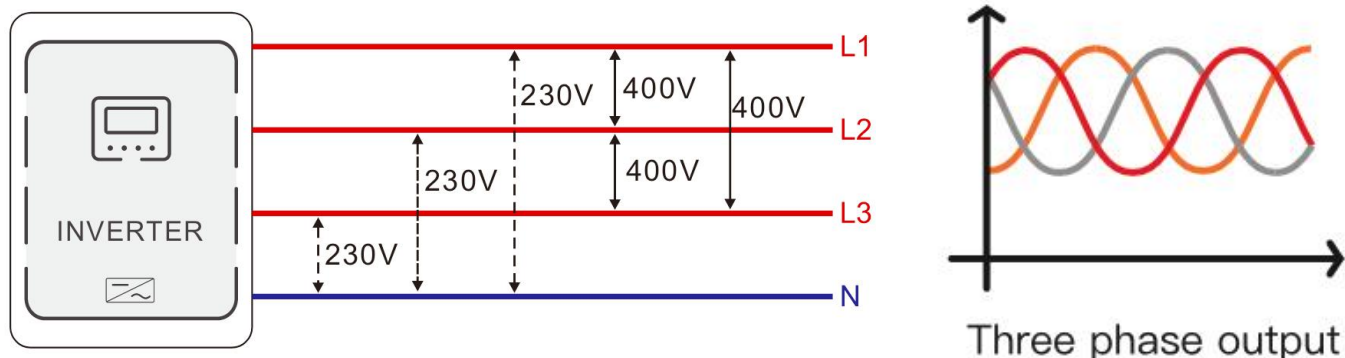

Project	Description
Applicable models	IESP series SH3 model
AC output phase voltage (L-N)	200~240Vac, 230Vac default

NOTICE

- Users can change the output voltage via the settings menu; for details, refer to Chapter 5.2.
- The output voltage corresponds to the parameter setting item [Work Mode] - [Output Phase Voltage], and the output phase voltage can be set within the range of 200V to 240V.

4.2 Cable & Circuit Breaker Selection

■ PV

Models	Cable Diameter	Max. Input Current	Circuit Breaker Spec
IESP500SH3	5mm ² / 10 AWG	40A	2P-50A
IESP550SH3	5mm ² / 10 AWG	40A	2P-50A
IESP600SH3	5mm ² / 10 AWG	40A	2P-50A

■ Battery

Models	Cable Diameter	Max. Input Current	Circuit Breaker Spec
IESP500SH3	21mm ² / 04 AWG	80*2A	Single Circuit 2P-100A / Dual Circuits 2P-200A
IESP550SH3	21mm ² / 04 AWG	80*2A	
IESP600SH3	21mm ² / 04 AWG	80*2A	

■ Grid

Models	Output Mode	Cable Diameter	Max. Input Current	Circuit Breaker Spec
IESP500SH3	Three-phase	42.4mm ² /1AWG(L1/L2/L3/N)	200A	4P-250A
IESP550SH3	Three-phase	42.4mm ² /1AWG(L1/L2/L3/N)	200A	4P-250A
IESP600SH3	Three-phase	42.4mm ² /1AWG(L1/L2/L3/N)	200A	4P-250A

■ Generator

Models	Output Mode	Cable Diameter	Max. Input Current	Circuit Breaker Spec
IESP500SH3	Three-phase	42.4mm ² /1AWG(L1/L2/L3/N)	200A	4P-250A
IESP550SH3	Three-phase	42.4mm ² /1AWG(L1/L2/L3/N)	200A	4P-250A
IESP600SH3	Three-phase	42.4mm ² /1AWG(L1/L2/L3/N)	200A	4P-250A

■ Load

Models	Output Mode	Cable Diameter	Max. Output Current	Circuit Breaker Spec
IESP500SH3	Three-phase	33.6mm ² /2AWG(L1/L2/L3/N)	130A	4P-200A
IESP550SH3	Three-phase	33.6mm ² /2AWG(L1/L2/L3/N)	130A	4P-200A
IESP600SH3	Three-phase	33.6mm ² /2AWG(L1/L2/L3/N)	130A	4P-200A

NOTICE

● AC input, AC output:

- ① Use a stripper to remove the 18-20mm insulation of the cable.
- ② Fixing a ferrule at the end of the cable

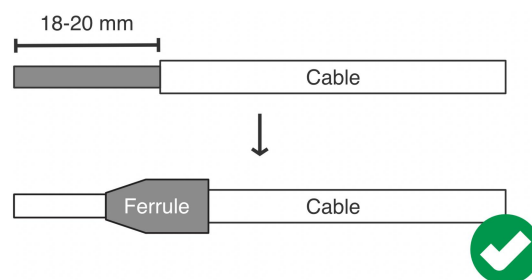

The wire diameter is for reference only. If the distance between the PV array and the inverter or between the inverter and the battery is long, using a thicker wire will reduce the voltage drop and improve the performance of the system.

4.3 Grid Input Connection

Connect the live, neutral and ground cables in the position and order of the cables as shown in the diagram below.

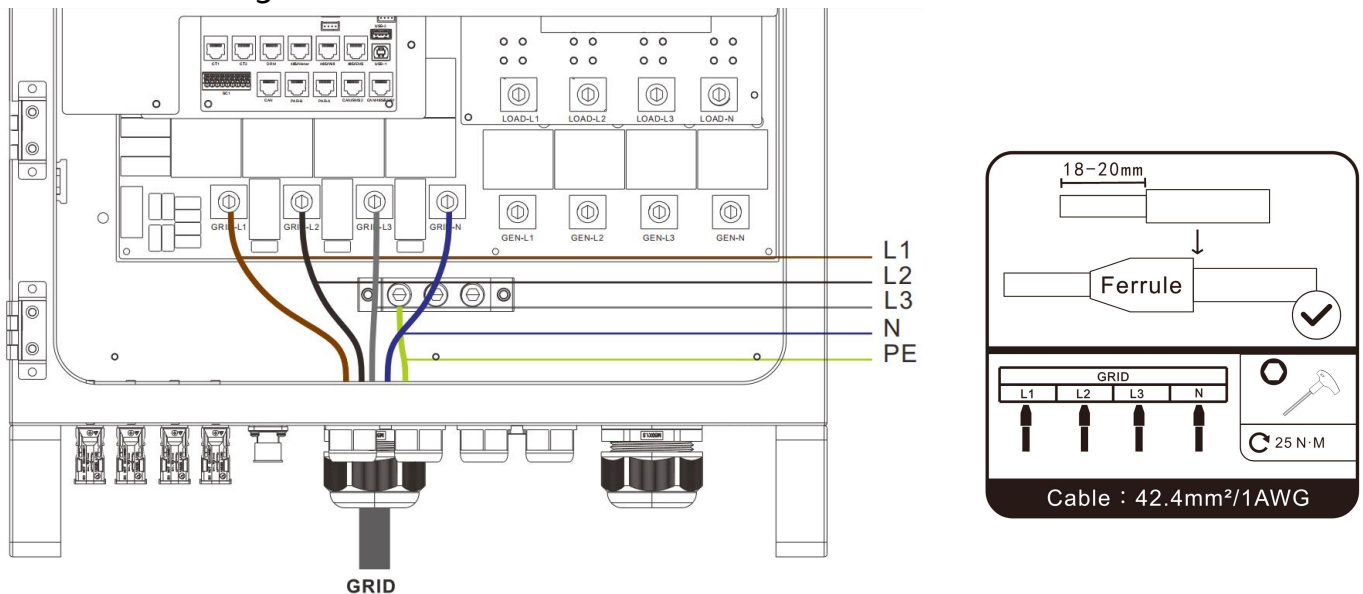

⚠ DANGER

- Before connecting the AC input, the circuit breaker must be disconnected to avoid electric shock hazards, and never operate with electricity.
- Please check that the cable used is sufficient for the requirements, too thin, poor quality cables are a serious safety hazard.

4.4 Load Output Connection

Connect the live, neutral and ground cables in the position and order of the cables as shown in the diagram below.

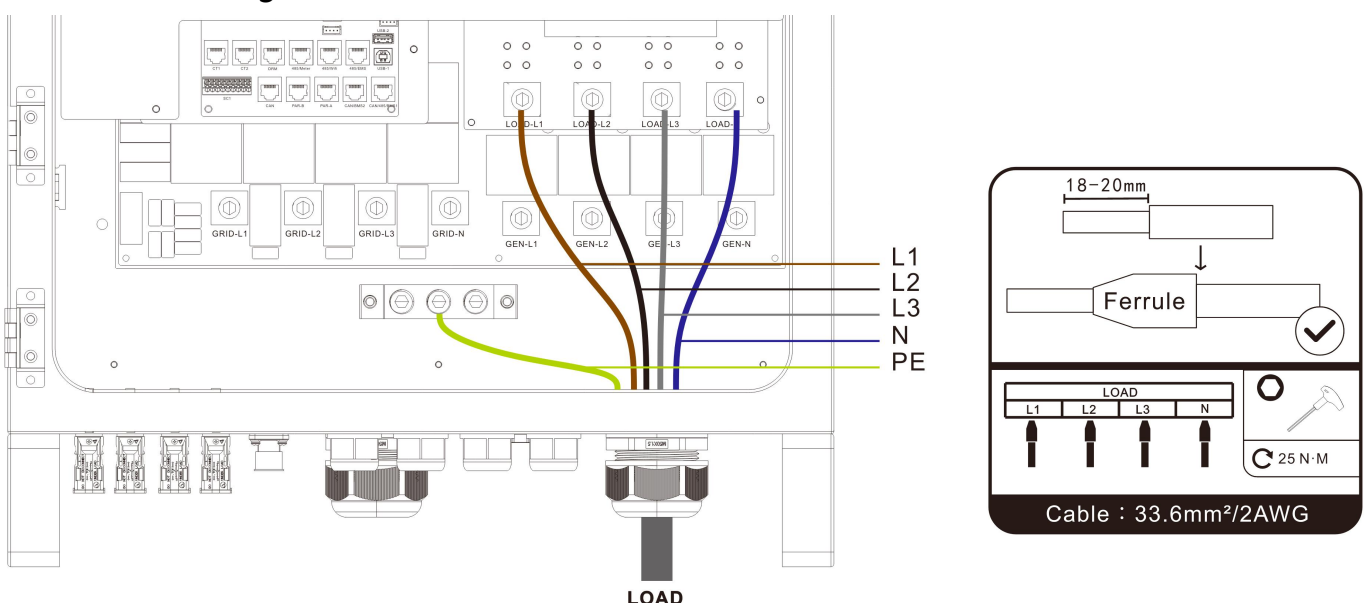

4.5 Generator Input Connection

Connect the live, neutral and ground cables in the position and order of the cables as shown in the diagram below.

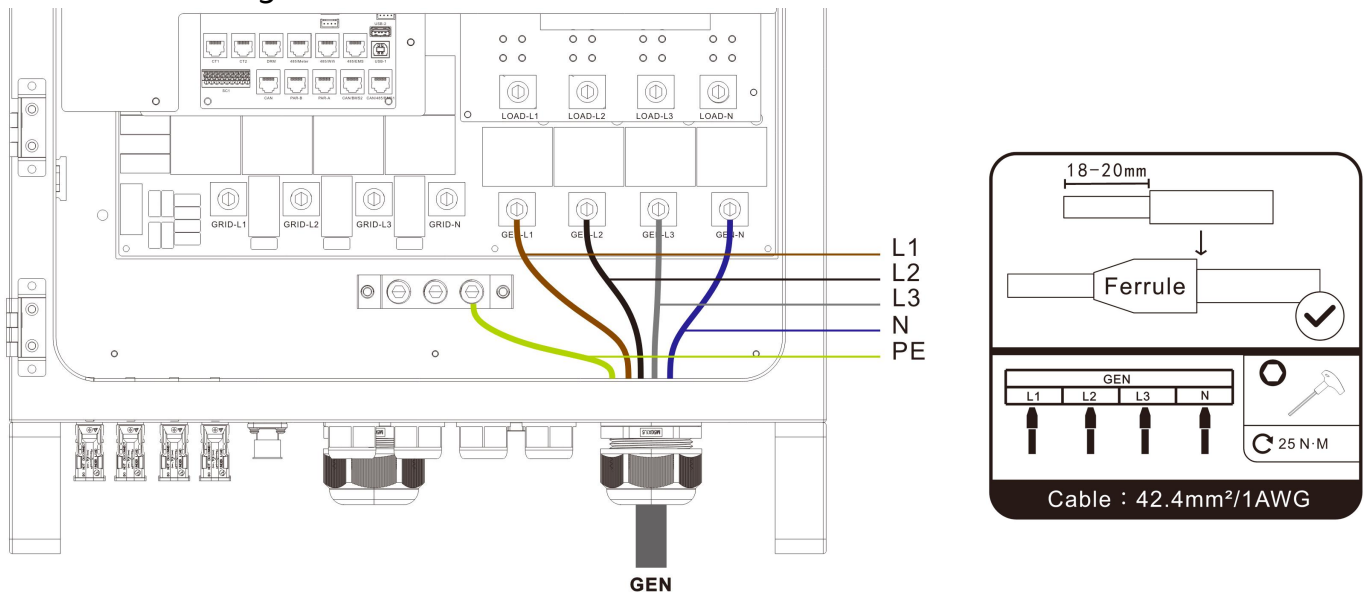

! DANGER

- Before connecting the AC input, the circuit breaker must be disconnected to avoid electric shock hazards, and never operate with electricity.
- Please check that the cable used is sufficient for the requirements, too thin, poor quality cables are a serious safety hazard.

4.6 Battery Connection

Connect the positive and negative cable of the battery according to the diagram below.

- **Step1:** Select the appropriate cable type and specification. The cable shall be stripped, and the specific stripping length is shown below Fig(1).
- **Step2:** Insert the tripped positive and negative power cables into the positive and negative terminal and crimp them using a clamping tool.
- **Step3:** Before connect the terminal please open the safety catch shown below fig(5).

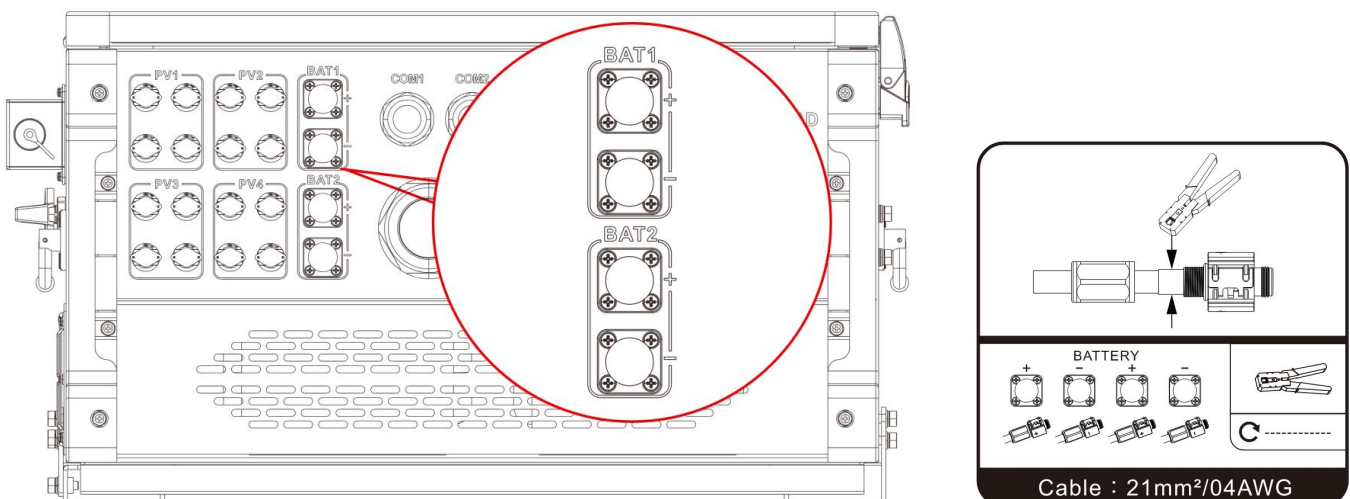

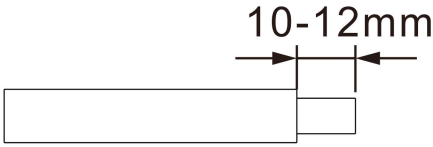
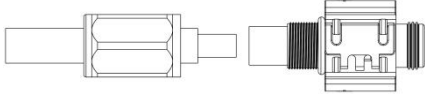
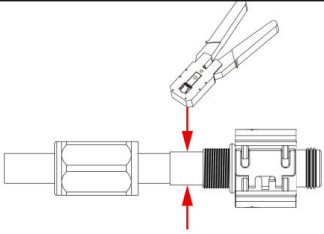
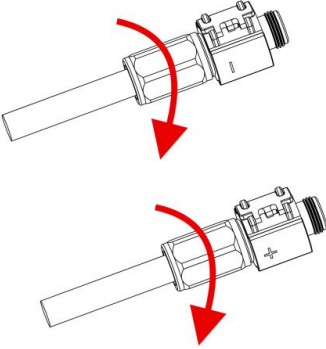
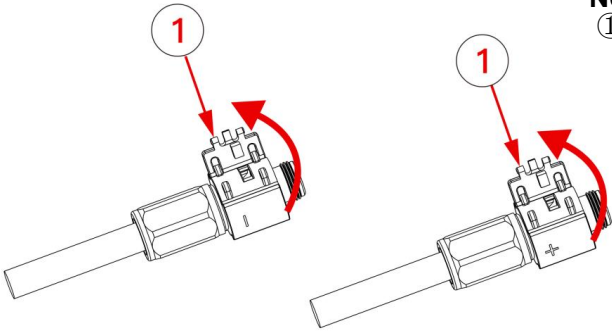
 <p>Fig. 1 Strip 10-12mm insulation off the cable</p>	 <p>Fig. 2 Pass the cable through the nut.</p>	 <p>Fig. 3 Crimp the cable tightly with a crimping tool.</p>
 <p>Fig. 4 Tighten the nut firmly.</p>	 <p>Fig. 5 Open the safety clip before connecting to the inverter, and fasten the clip securely after installation.</p> <p>Note: ① safety buckle</p>	

⚠ DANGER

- Before connecting the battery, the circuit breaker must be disconnected to avoid electric shock hazards, and live operation is strictly prohibited.
- Please ensure that the positive and negative poles of the battery are connected correctly. Do not reverse the connection, otherwise the inverter may be damaged.
- Please check that the cable used is sufficient for the requirements, too thin, poor quality cables are a serious safety hazard.
- The lengths of the two sets of battery cables connected to the inverter should be as consistent as possible; otherwise, current imbalance may occur.

4.7 PV Connection

1. Before connecting PV, first close the external circuit breaker and make sure that the cable used is sufficiently thick. Please refer to section "4.2 Cable & Circuit Breaker Selection".
2. Correctly connect the PV input wires according to the cable sequence and terminal positions shown in the figure below. When using in parallel, different machines need to be connected to different PV arrays or PV sources.

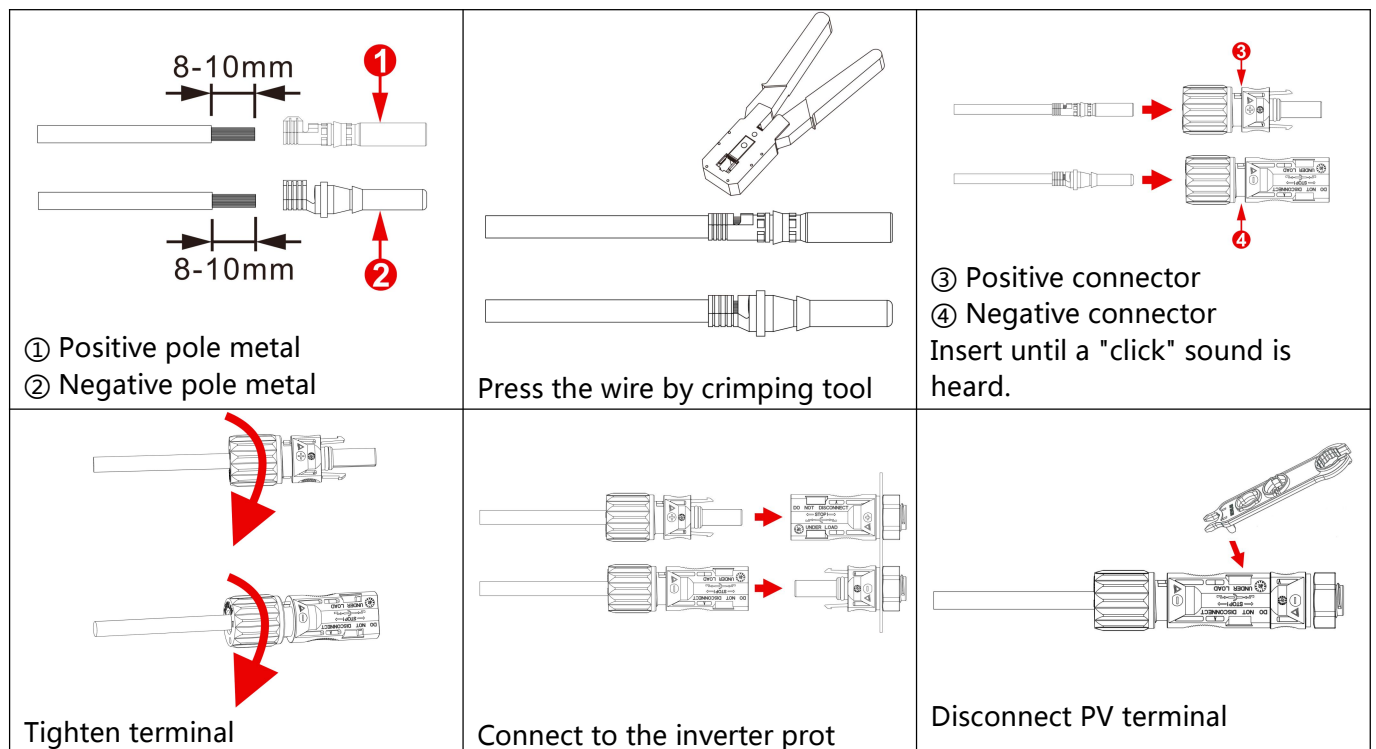
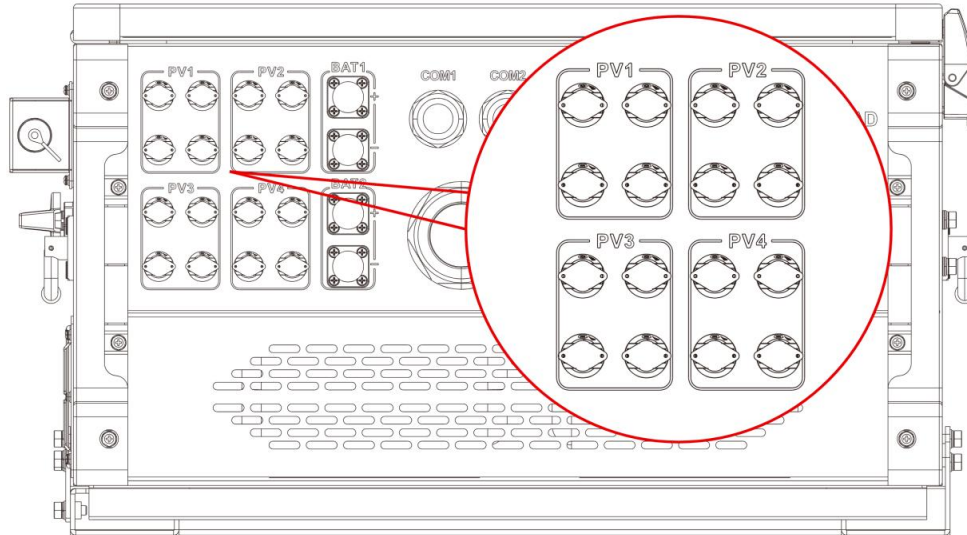

DANGER

- Before connecting the PV, the circuit breaker must be disconnected to avoid the risk of electric shock and must not be operated with electricity.
- Make sure that the open-circuit voltage of the PV modules connected in series does not exceed the max. open-circuit voltage of the inverter (the value is 1000V), otherwise the inverter may be damaged.

4.8 Dry Contact Connection

Use a small screwdriver to push backward in the direction of the arrow, and insert the communication cable into the dry contact port.

Communication cable diameter: 0.2~1.5mm²

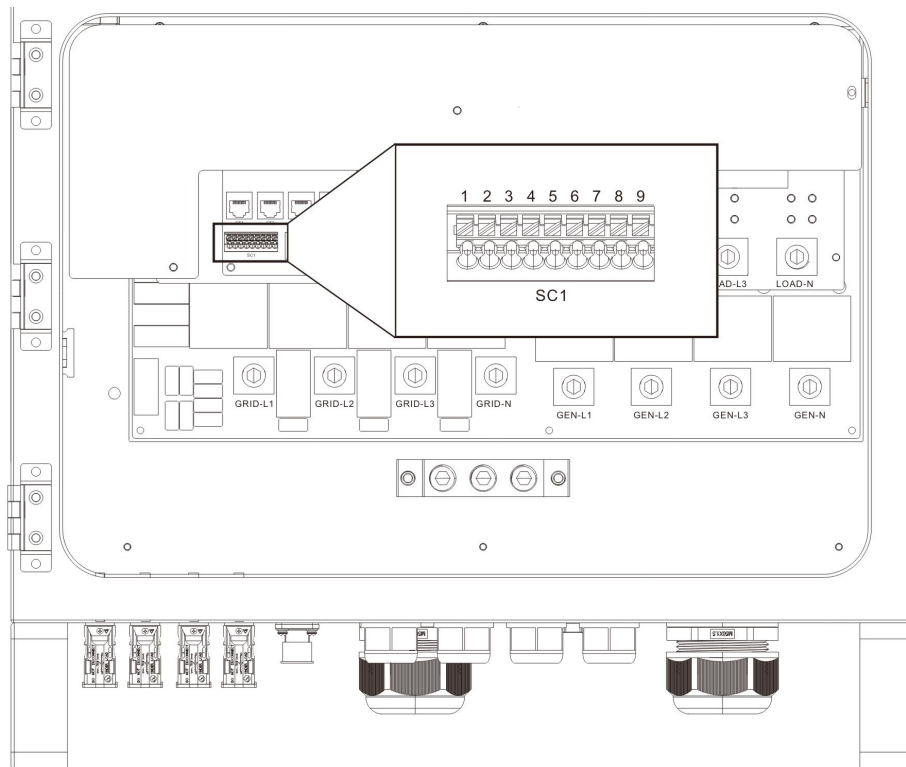

4.9 Grounding Connection

Please make sure the grounding terminal connect to the Grounding Bar.

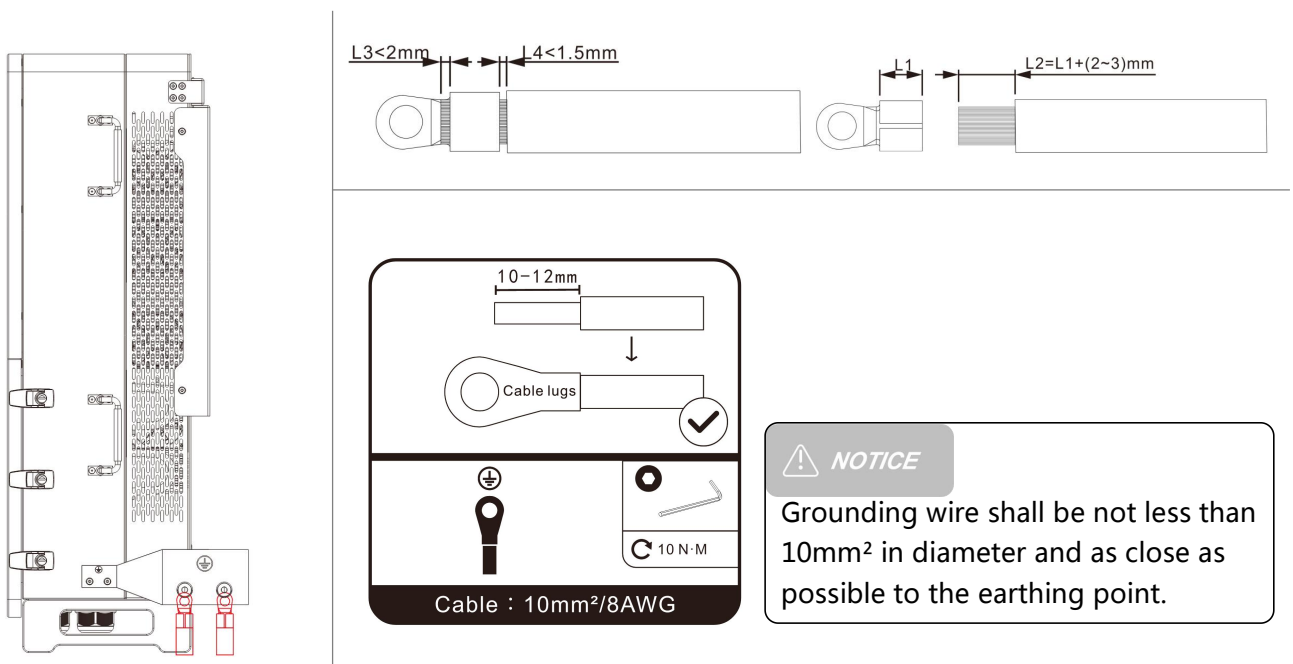

4.10 Inverter Start

After ensuring that the wiring is reliable and the wire sequence is correct, restore the terminal protection cover to its original position.

- **Step 1:** Close the circuit breaker of the battery.
- **Step 2:** Press the ON/OFF switch on the side of the inverter. The screen and indicator lights turning on indicates that the inverter has been activated.
- **Step 3:** Sequential close of the circuit breakers for PV, AC input and AC output.
- **Step 4:** Start the loads one by one in order of power from small to large.

4.11 Parallel Connection

4.11.1 Introduction to Parallel Connection

1. Up to 9 units connected in parallel.
2. When using the parallel operation function, the following connecting lines (package accessories) shall be firmly and reliably connected.

Parallel Communication Cable * 1

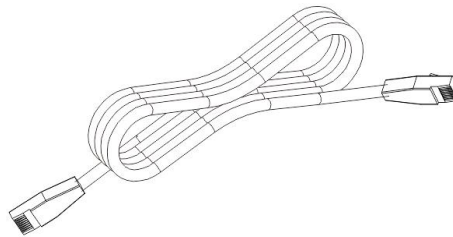

4.11.2 Precautions for Connecting Parallel Connection Cables

1.PV connection:

When connecting in parallel, the PV array of each inverter must be independent.

2.Battery connection:

When connecting in parallel, the battery of each inverter must be independent.

3.Load connection:

In three-phase parallel connections, all solar energy storage inverters must be connected with N to N and PE to PE. The AC output L lines of the same phase should be connected together. The wiring method is the same when using a generator as a smart load.

4.Grid connection:

In three-phase parallel connections, all solar energy storage inverters must be connected with N to N and PE to PE. The grid L lines of the same phase should be connected together. The wiring method is identical when using a generator as an input source or for micro-inverters.

5.Communication lines:

Our parallel communication cable is a shielded 8-pin network cable suitable for three-phase parallel connections. Each unit must have one input and one output connection. Specifically, Unit "Parallel_A" should be connected to Unit "Parallel_B" for parallel operation. Direct connections from "Parallel_A" back to itself or another "Parallel_A" unit, or improper loops between "Parallel_A" and "Parallel_B," are strictly prohibited. Additionally, secure each unit's parallel communication cable firmly to the 8-pin network connector to prevent disconnections or poor contacts, which may lead to abnormal system operation or damage to the output.

6. Before and after connecting the system, carefully refer to the system wiring diagram below. Ensure all connections are correct and secure before powering on.

7. After the system is correctly wired, powered on, and operating normally, if a new inverter needs to be connected, ensure that the battery input, PV input, AC input, and AC output are disconnected, and all solar energy storage inverters are powered off before reconnecting to the system.

4.11.3 Schematic of Three-Phase Parallel Operation

Set the parallel mode of each inverter to "Parallel".

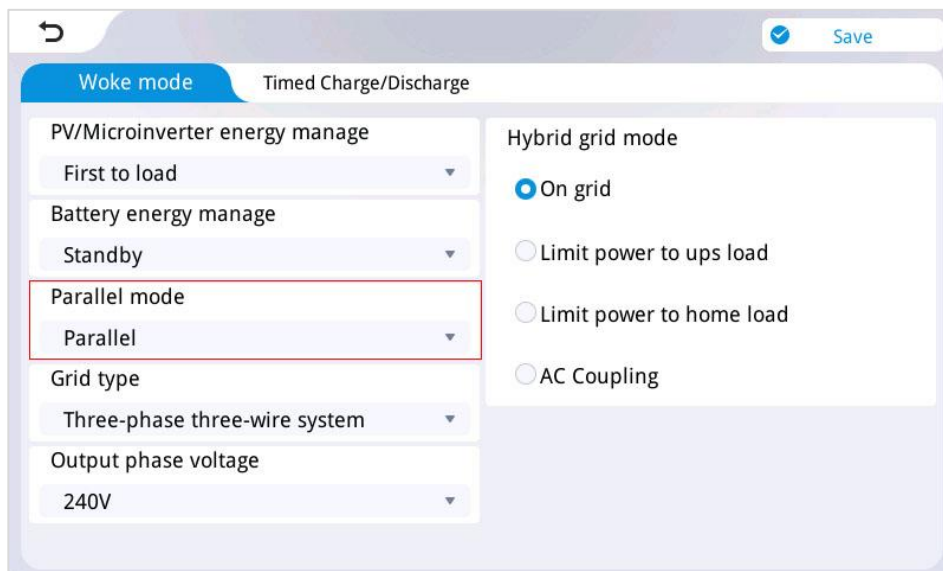

a) Two units connected in parallel:

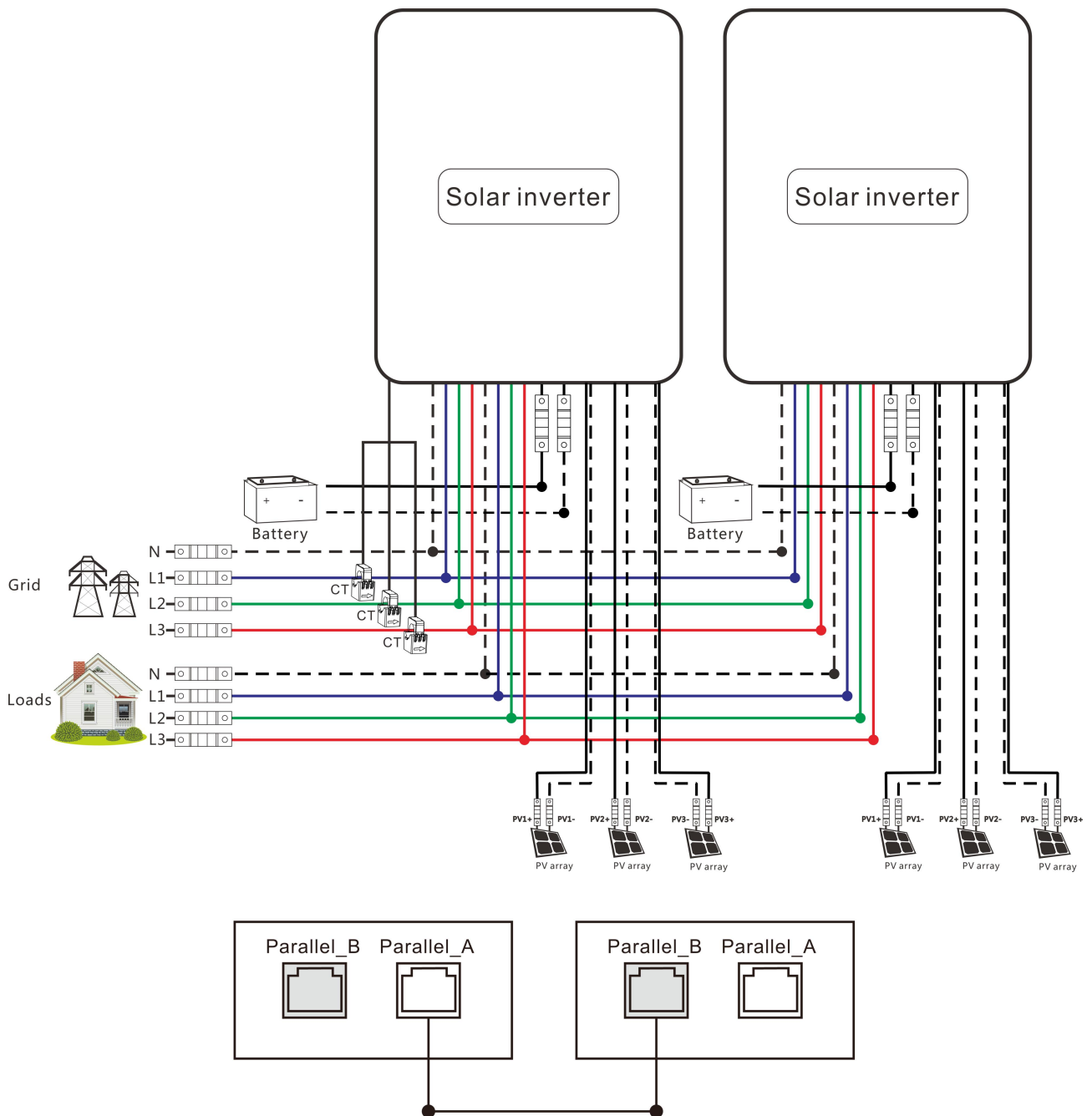

⚠ DANGER

- Each energy storage inverter must be connected to an independent battery pack.
- For three-phase parallel connection, all solar energy storage inverters shall be connected in the way of N to N and PE to PE. The grid L-lines of the same phase shall be connected together. The wiring method is the same when connecting to a diesel generator input or microinverters.

b) Multiple units connected in parallel:

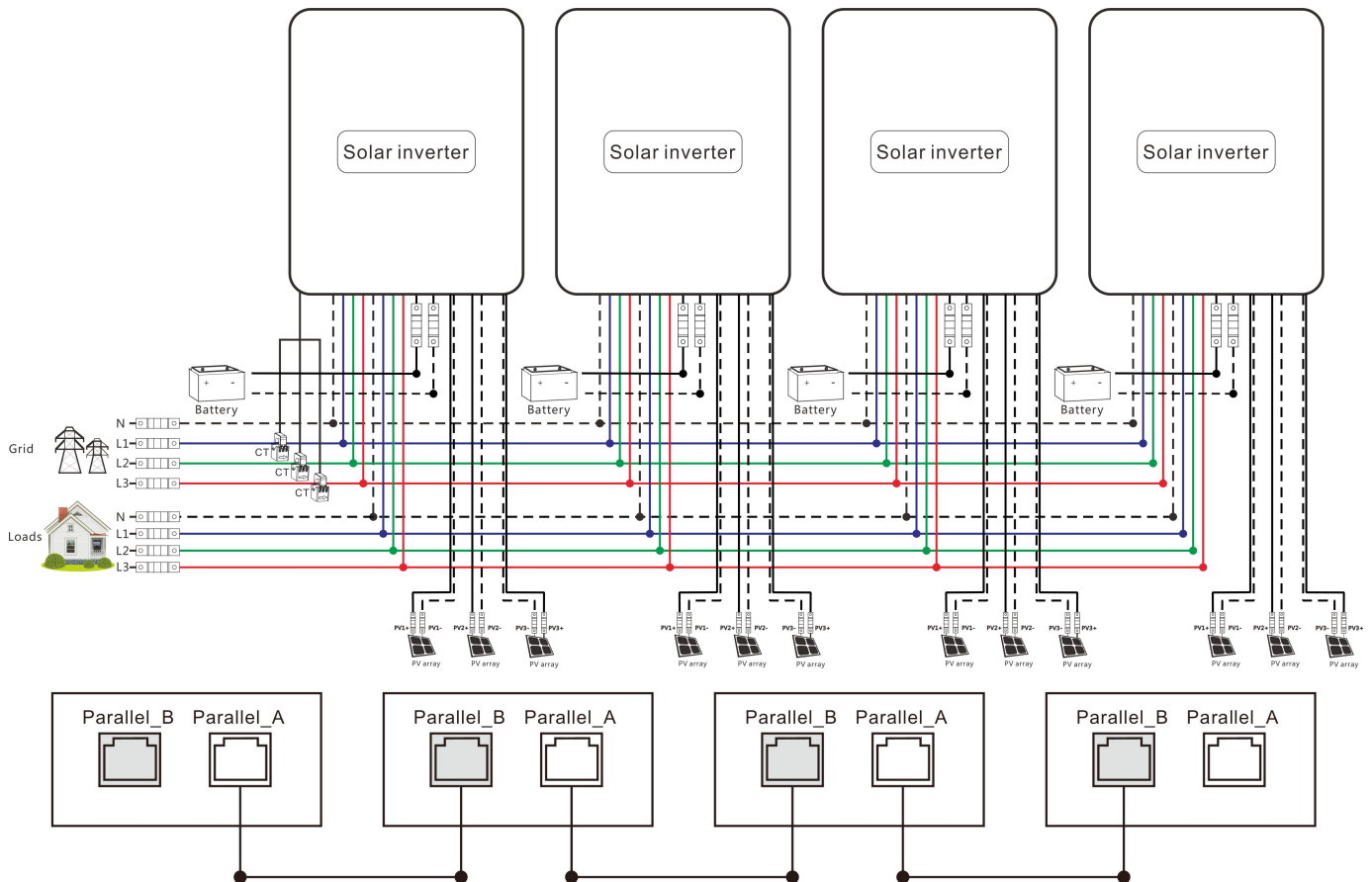

DANGER

- Each energy storage inverter must be connected to an independent battery pack.
- For three-phase parallel connection, all solar energy storage inverters shall be connected in the way of N to N and PE to PE. The grid L-lines of the same phase shall be connected together. The wiring method is the same when connecting to a diesel generator input or microinverters.



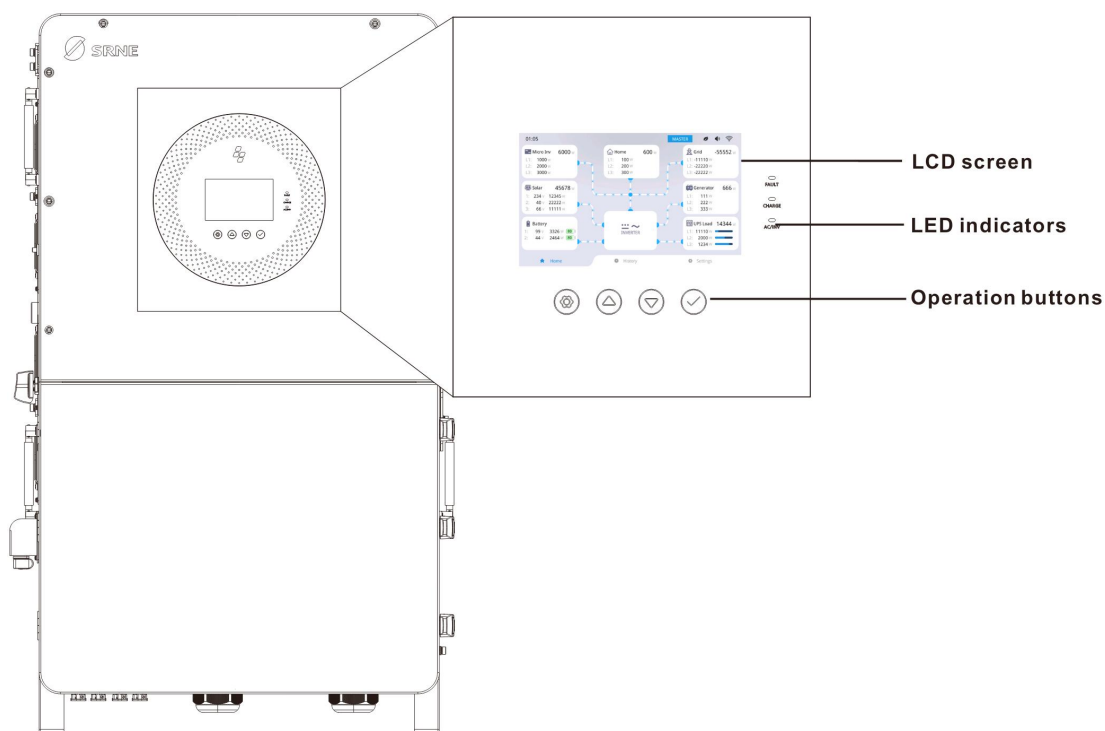

5. Operation

5.1 Operation and Display Panel

The inverter's operation and display panel includes 1 LCD screen, 3 LED indicators, and 4 Operation buttons.



■ Operation buttons

Button	Description
	To enter/exit the setting menu
	To last selection
	To next selection
	To confirm/enter the selection in setting menu

■ LED indicators

Indicator	Color	Description
FAULT	Red	Flashing: Error occurred
CHARGE	Green	Continued: Charging completed
		Flashing: Charging in progress
AC/INV	Yellow	Continued: Utility grid bypass output
		Flashing: Inverter output

■ Display Panel



Icon	Description	Icon	Description
	Microinverter		Grid
	Solar Panel		Generator
	Battery		UPS Load
	Household Load		Inverter
	Home Page		Energy Saving Mode
	Historical Data		Settings
01 : 05	Local Time		Buzzer
	WiFi Status		Energy Flow
MASTER	Main Unit Logo		

■ View real-time data

On the LCD home screen, click the inverter icon, battery icon, grid icon, generator icon, UPS load icon, or PV icon allows viewing of real-time data for each component. The microinverter and household load icons are non-clickable, as their data is fully displayed on the home page.

Inverter Data			
NO.	Real-Time Data Item	NO.	Real-Time Data Item
1	Main CPU 1	2	Main CPU 2
3	Minor Version	4	Slave CPU
5	Inverter Rated Power	6	Inverter RS485 Address

7	Inverter Customer ID	8	Inverter LCD Version
9	Busbar Positive Voltage	10	Busbar Negative Voltage
11	Total Busbar Voltage	12	SN Code
13	Machine Status	14	Solar Temperature
15	Battery Temperature	16	Inverter Temperature
17	External Temperature	18	Local Load Total Parallel Power
19	Home Load Total Parallel Power	20	Grid Total Parallel Power
21	Generator Total Parallel Power	22	L1 Voltage
23	L2 Voltage	24	L3 Voltage
25	L1 Current	26	L2 Current
27	L3 Current		
Solar Data			
1	Solar1 Voltage V	2	Solar1 Current A
3	Solar1 Power W	4	Solar2 Voltage V
5	Solar2 Current A	6	Solar2 Power W
7	Solar3 Voltage V	8	Solar3 Current A
9	Solar3 Power W	10	Solar4 Voltage V
11	Solar4 Current A	12	Solar4 Power W
13	Solar Total Power		
Battery Data			
1	Battery 1 Voltage	2	Battery 1 Charging/Discharging Power
3	Battery 1 Charging/Discharging Current	4	Battery 1 SOC (%)
5	Battery 1 Type	6	Battery 1 BMS Protocol
7	Battery 1 Status	8	BMS1 Data
9	Battery 2 Voltage	10	Battery 2 Charging/DischargingPower
11	Battery 2 Charging/Discharging Current	12	Battery 2 SOC (%)
13	Battery 2 Type	14	Battery 2 BMS Protocol
15	Battery 2 Status	16	BMS2 Data
Grid Data			
1	L1 Voltage	2	L1 Current
3	L1 Active Power	4	L1 Apparent Power
5	L2 Voltage	6	L2 Current
7	L2 Active Power	8	L2 Apparent Power
9	L3 Voltage	10	L3 Current
11	L3 Active Power	12	L3 Apparent Power

13	L1 CT Power	14	L2 CT Power
15	L3 CT Power	16	Frequency
Generator Data			
1	L1 Voltage	2	L1 Current
3	L1 Active Power	4	L1 Apparent Power
5	L2 Voltage	6	L2 Current
7	L2 Active Power	8	L2 Apparent Power
9	L3 Voltage	10	L3 Current
11	L3 Active Power	12	L3 Apparent Power
13	Frequency		
UPS Load Data			
1	L1 Voltage	2	L1 Current
3	L1 Active Power	4	L1 Apparent Power
5	L2 Voltage	6	L2 Current
7	L2 Active Power	8	L2 Apparent Power
9	L3 Voltage	10	L3 Current
11	L3 Apparent Power	12	L3 Active Power
13	L1 Load Rate	14	L2 Load Rate
15	L3 Load Rate	16	Overall Load Rate
17	Frequency		
Smart Load Data			
1	L1 Voltage	2	L1 Current
3	L1 Active Power	4	L1 Apparent Power
5	L2 Voltage	6	L2 Current
7	L2 Active Power	8	L2 Apparent Power
9	L3 Voltage	10	L3 Current
11	L3 Apparent Power	12	L3 Active Power
13	Frequency		
History Data			
1	Today Data	2	History
3	Energy Statistics	4	History Fault

■ Browsing Detailed Data with Buttons

1. Press the up/down buttons, and when "**HOME**" is highlighted in blue, press the **confirm** button to select the home page icon.

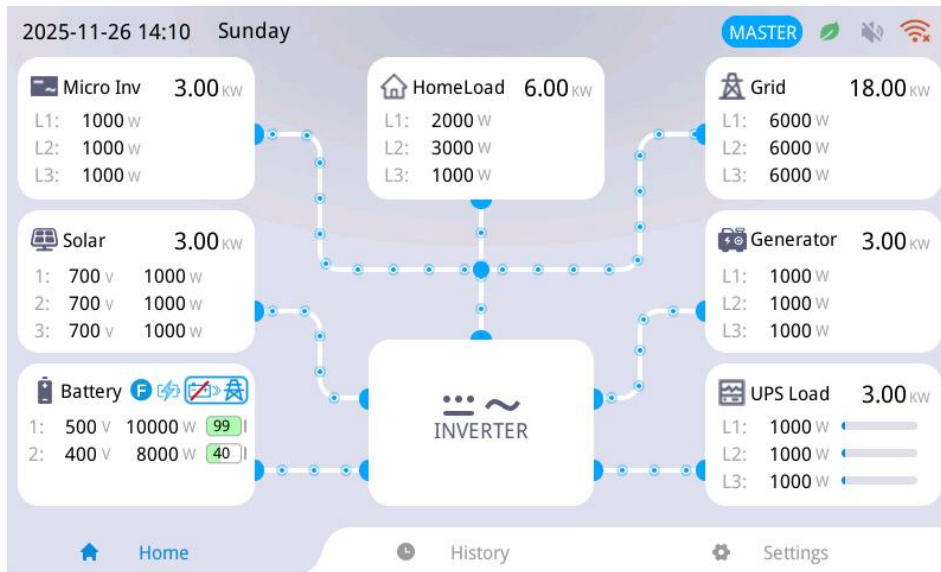

2. After selecting the home page icon, press the confirm button again to enter the data details page.

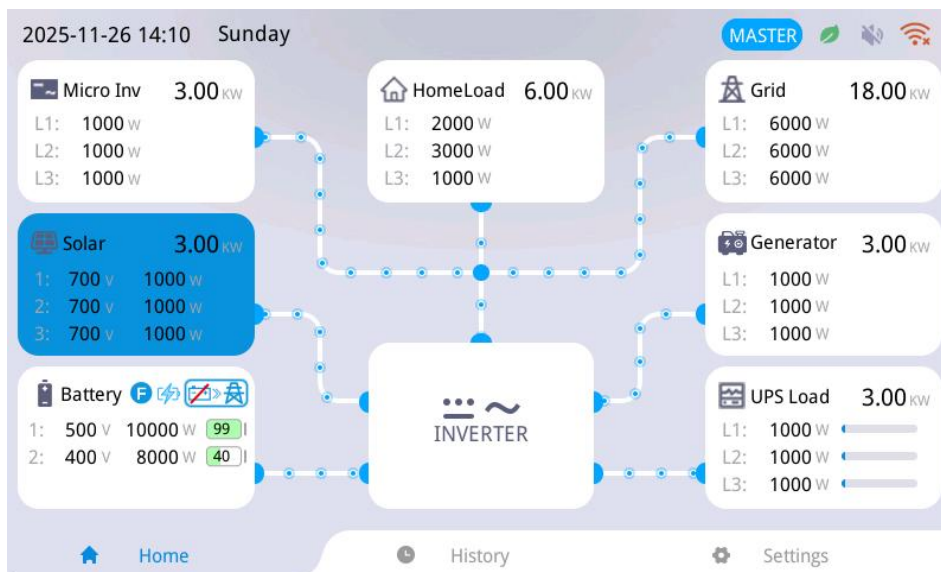

5.2 Setting Parameters

Operation Instructions:

1. Click the "Settings" button in the bottom menu bar of the screen to enter the settings interface. It includes seven categories: "**Basic setup**", "**Work mode setup**", "**Battery setup**", "**On-grid setup**", "**Advance setup**", "**WiFi setup**", and "**Firmware Upgrade**".
2. When modifying settings, if password protection is enabled, you must enter the password to change parameters. The default password is "4321".

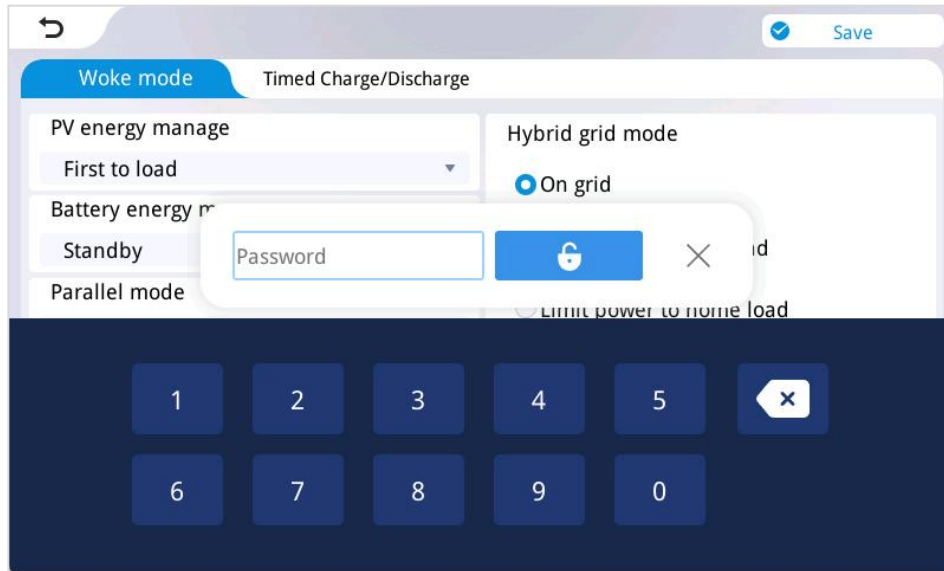

■ Setting Flow Chart:

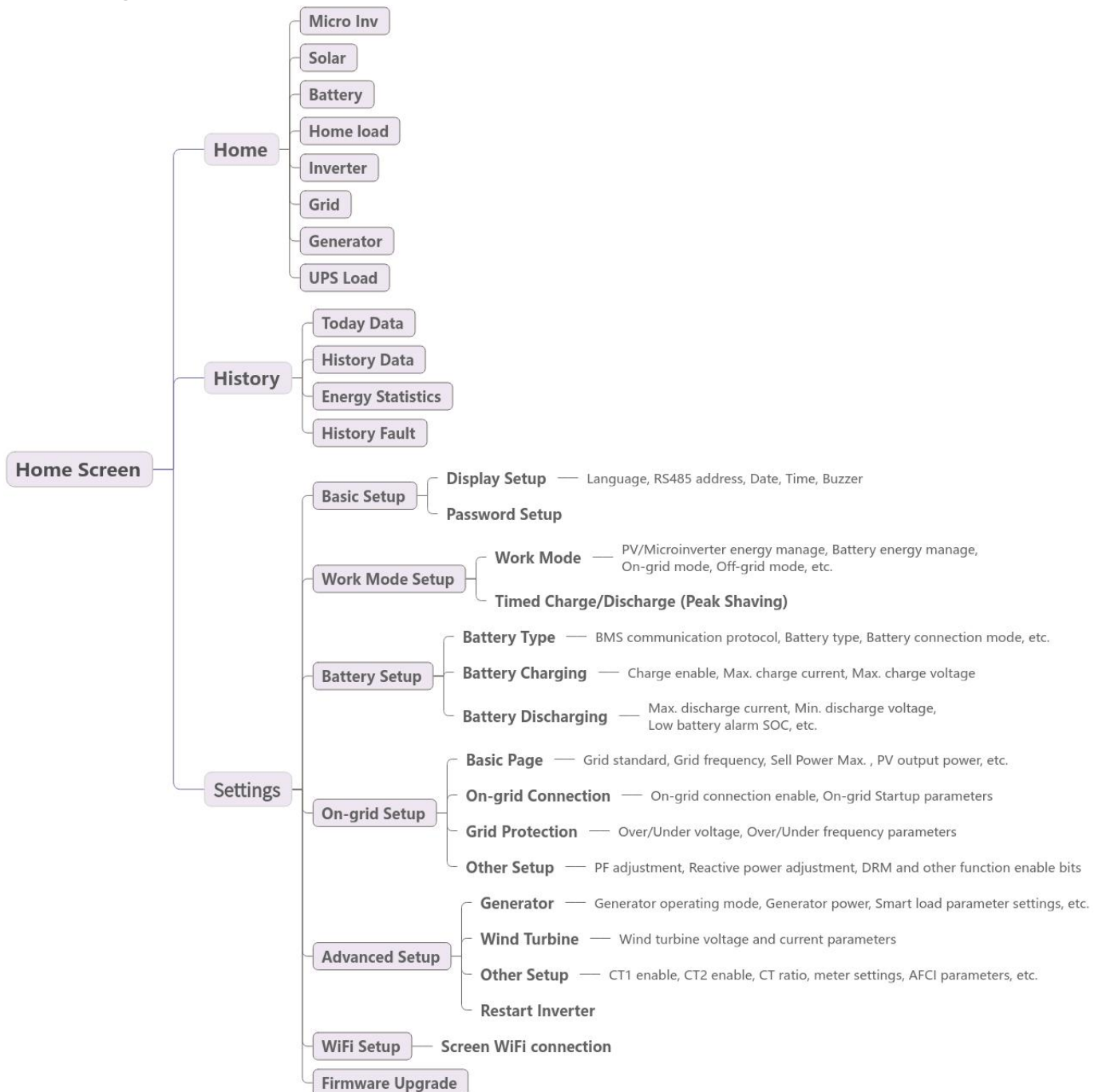

5.2.1 Basic Setup

5.2.1.1 Display Setup

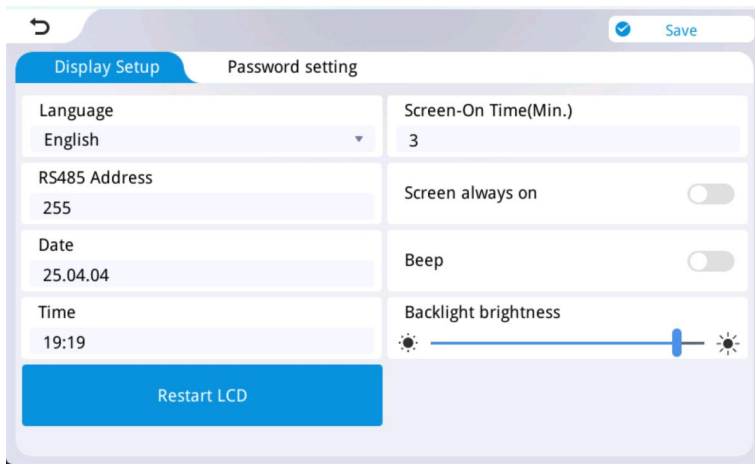

- **Language:** English, Italian, German, Spanish, Chinese.
- **RS485 Address:** RS485 address of the inverter.
 - ① Single device: Adjustable range 1~254.
 - ② Parallel devices: Adjustable range 1~9.
- **Date:** Set year, month, day.
- **Time:** Set hour and minute.
- **Screen-On Time(Min.):** Adjustable range 1~30 minutes.
- **Screen always On:** Select whether the screen stays on continuously.

- **Beep:** Select whether to enable buzzer alarm.
- **Backlight brightness:** Adjustable from 0~100%.
- **Restart LCD:** Restart the Screen

5.2.1.2 Password Setup (Change Password)

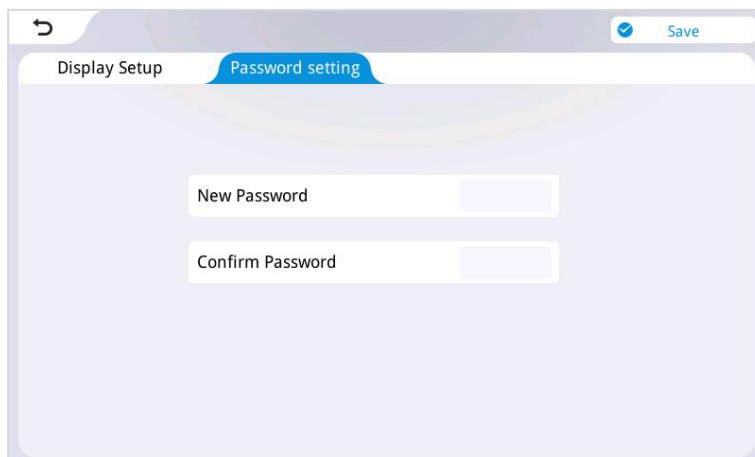

- **New Password:** Enter your custom new password.
- **Confirm Password:** Please re-enter the new password exactly as above to verify the accuracy of the password setting.

5.2.2 Work Mode Setup

5.2.2.1 Work Mode

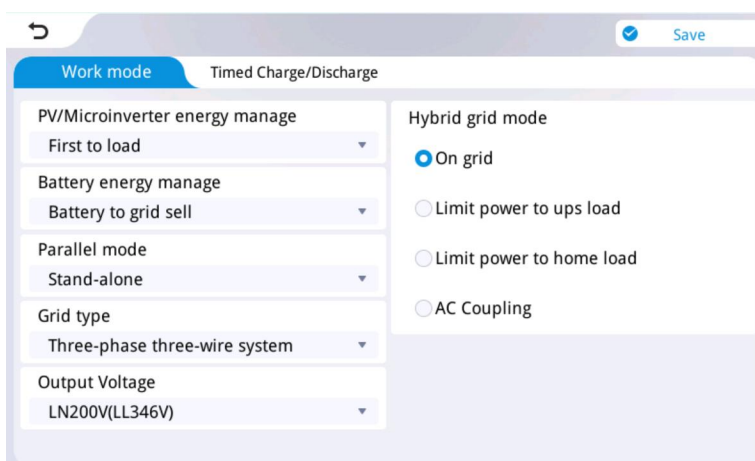

- 1. UPS Load:** Connected to the LOAD port of the machine.
- 2. Smart Load:** Refers to the load connected to the machine's GEN port. (Only valid when the GEN port is set to the smart load function.)
- 3. Home Load:** Refers to the load connected to the machine's GRID port, which requires external CT or energy meter for use. (Otherwise, the power of the Home load cannot be detected.)

This is the detailed page of "Work Mode"		
Parameter Meaning	Options	Description
Hybrid grid mode	On grid	Direct grid connection of excess PV energy.
	Limit power to UPS load	In this mode, solar or battery energy is only used for UPS load and smart load, Excess energy will not be fed into the grid (UPS load is reverse-flow protected).
	Limit power to home load	In this mode, solar or battery energy is used only for the UPS load, smart load, and home load. Excess energy will not be fed into the grid (HOME load is reverse-flow protected).
	AC Coupling	This mode is used to add AC coupling functionality to on-grid inverters. The on-grid inverter needs to be connected to the grid side of the hybrid inverter (effective only when the GEN port is not set to micro-inverter mode); or connected to the generator side of the hybrid inverter (effective only when the GEN port is set to micro-inverter mode). In this mode, the hybrid inverter will use the grid energy from the on-grid inverter to power loads or charge batteries.
PV/Microinverter energy manage	When the hybrid grid mode is set to "Limit power supply to UPS load" or when CT1 is not connected, the meter is not communicating, or communication fails (effective only when the meter detection location is set to the grid side), the subsequent loads refer to the UPS load and smart load. When the hybrid grid mode is set to "Limit Home Load/Grid Power Supply" and CT1 is successfully connected or the meter communication is successful (effective only when the meter detection location is set to the grid side), the subsequent loads refer to the UPS load, smart load, and home load.	
	First to Load	PV energy priority: load>charge>on grid. Micro-inverter energy priority: load>charge>on grid.
	First to charging	PV energy priority: charge>load>on grid. Micro-inverter energy priority: load>charge>on grid.
	First to grid	PV energy priority: load>on grid>charge. Micro-inverter energy priority: load>on grid>charge.
Battery energy manage	Standby	The battery does not discharge, and the battery is discharged only when the working state is off the grid.
	Battery to UPS load	The battery can supply power to the UPS load, smart load, and home load, but does not participate in selling power to the grid.
	Battery to home load	The battery powers UPS loads, smart loads, and household loads, but does not participate in grid selling.
	Battery to grid sell	The battery can supply power to the UPS load, smart load, and home load, and participate in selling power to the grid.
Parallel mode	Stand-alone.	
	Parallel operation.	
Grid type	Three-phase three-wire system.	
	Three-phase four-wire system.	
Output voltage	Settable: 200V,208V,220V,230V,240V	

5.2.2.2 Timed Charge/Discharge

The screenshot shows the 'Timed Charge/Discharge' configuration page. It is divided into two main sections: 'Timed charging enable' and 'Timed discharging enable'. Each section has a table with columns for Start Time, End Time, Stop SOC, Stop Volt, and Max Power. There are also checkboxes for 'Grid' and 'Gen' charging sources. Below these tables, there is a 'Max consumption enable' checkbox. The second part of the screenshot shows a 'Weekly Enable' section with toggle switches for Monday, Tuesday, Wednesday, Thursday, Friday, Saturday, and Sunday.

- **Timed charging enable:** Select whether to enable scheduled charging.
- **Timed discharging enable:** Select whether to enable scheduled discharging.
- **Start/End Time:** Set the time period for scheduled charging/discharging.
- **Stop SOC:** Set the battery's cutoff SOC values for charging/discharging during the scheduled charging/discharging time periods. (effective when BMS communication is successful).
- **Stop Volt:** Set the battery's cutoff voltage values for charging /discharging during the scheduled charging/ discharging time periods. (effective when BMS communication is not established or fails).
- **Max. Power:** Setting the battery charging power and discharging power during the scheduled charging and discharging time period.
- **Grid:** Allow the grid to charge the battery during the scheduled charging period.
- **Gen:** Allow the generator to charge the battery during the scheduled charging period.

- **Max. consumption enable:** Allow the battery to discharge outside the scheduled discharging period.
- **Weekly Enable:** Set the days of the week for scheduled charging/discharging (only valid for scheduled charging/discharging).

5.2.3 Battery Setup

5.2.3.1 Battery Type

The screenshot shows the 'Battery Type' configuration page. It has two columns: 'Battery Charging' and 'Battery Discharge'. Under 'Battery Charging', there are dropdowns for 'BMS1 comm. interface' (set to CAN), 'BMS1 comm. protocol' (set to SHOTO), 'Battery type' (set to Lithium Battery), and a 'SOC Balance Factor' of 1. There is a toggle for 'Batt. chg. temp compensation' which is turned on. Under 'Battery Discharge', there are dropdowns for 'BMS2 comm. interface' (set to CAN) and 'BMS2 comm. protocol' (set to PYL_CAN). There is a 'Battery connection method' dropdown (set to Parallel Battery Input), a 'Grid-Tied Discharge SOC Balance Enable' toggle (turned on), and a 'Grid-charging SOC Balance Enable' toggle (turned on).

- **BMS1/2 comm. interface:**
 - ① **Disable:** BMS communication disabled.
 - ② **RS485:** BMS RS485 communication.
 - ③ **CAN:** BMS CAN communication.
- **Battery Type:**
 - ① **USER define:** All battery parameters can be customized by the user.
 - ② **Lithium Battery:** Lithium Battery.
 - ③ **No battery:** No battery connected.
- **Batt. chg temp compensation:** Used to select whether to enable temperature compensation

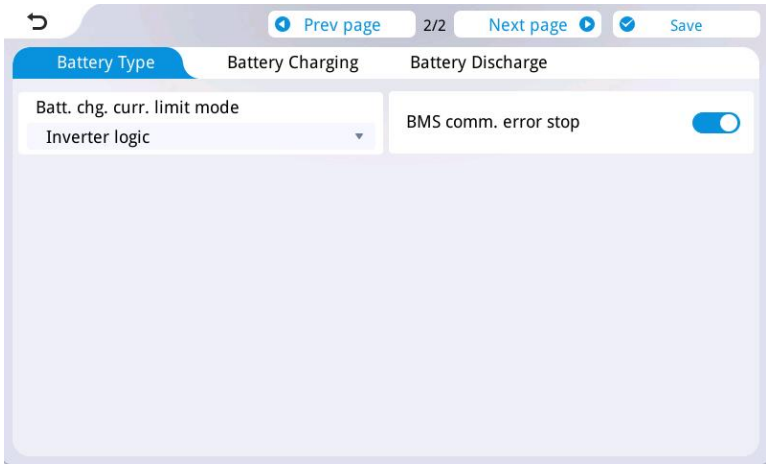

● **Battery chg. curr. limit mode(valid for BMS communication):**

- ① HMI setting: The max. battery charging current is limited by the charging current setting value of the inverter.
- ② BMS setting: The max. battery charging current is restricted by the current limit value of the BMS.
- ③ Inverter logic: The max. battery charging current is limited by the derating logic of the device.

- **BMS1/2 comm. protocol:** When the BMS port selection is set to CAN, the corresponding lithium battery manufacturer's brand must be selected for communication.

CAN protocol: UZE; WOW_CAN; Pyl_CAN; DYNESS; SHOTO

Note: Please refer to the actual display on the screen.

5.2.3.2 Battery Charging

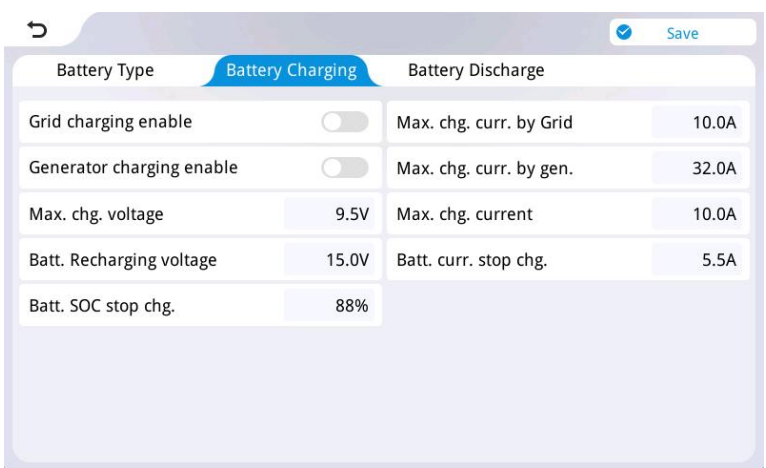

- **Grid charging enable:** Select whether to allow the grid to charge the battery (not applicable to scheduled charging).

- **Generator charging enable:** Select whether to allow the generator to charge the battery (not applicable to scheduled charging).

- **Max. chg. voltage:** Set the maximum charging voltage during constant voltage charging of the battery.

- **Batt. Recharging voltage:** After the battery is fully charged, the inverter stops charging. Charging resumes when the battery voltage drops below this value. (This setting is effective when BMS communication is not established or has failed.)
- **Batt. SOC stop chg.:** When the SOC reaches the specified value, battery stops charging. (Valid when BMS communication is normal).
- **Max. chg. curr. by Grid:** Set the maximum charging current from the grid to the battery. (**Note:** This value refers to the battery-side current, not the grid-side current, and does not apply to scheduled charging.)
- **Max. chg. curr. by gen.:** Set the maximum charging current from the generator to the battery. (**Note:** This value refers to the battery-side current, not the generator-side current, and does not apply to scheduled charging.)
- **Max. chg. current:** Set the maximum charging current during the constant current phase of battery charging.
- **Batt. curr. stop chg.:** During the constant voltage charging phase, charging will cease when the charging current falls below this value. (Effective when BMS communication is not performed or BMS communication fails).

Note: After the battery is fully charged, the inverter stops charging. Charging will resume when the battery SOC drops below this value. (Fixed at Battery Charging Stop SOC - 5%, non-modifiable, effective when BMS communication is normal)

5.2.3.3 Battery Discharging

Battery Type	Battery Charging	Battery Discharge	
Batt. volt. stop dischg. in hybrid	9.0V	Batt. SOC stop dischg. in hybrid	11%
Batt. volt. restart dischg.	10.0V	Batt. SOC restart dischg.	55%
Batt. under volt. alarm	20.0V	Batt. under capacity alarm	33%
Batt. volt. low recovery	34.5V	Batt. SOC low fault	44%
Batt. voltage low fault	6553.5V	Batt. volt. low delay	2570S
Batt. max. curr. dischg.	5.5A		

- **Batt. under volt. alarm:** When the battery voltage is lower than this value, the inverter will report an under-voltage alarm (Notify the user that the battery is about to stop discharging), but the battery will not stop discharging. (Effective when BMS communication is not established or fails.)
- **Batt. volt. low recovery:** When the battery report voltage low fault, the battery voltage reach this setting, the fault will be cleared.

- **Batt. under capacity alarm:** SOC value up to this setting will alarm. The inverter output will not shut down and the fault disappears if the SOC value exceeds 5% of the set value. (Valid when BMS communication is normal)
- **Batt. SOC low fault:** When the battery SOC is lower than this value, the inverter will report a low battery SOC fault and stop discharging. (Effective when BMS communication is normal.)
- **Batt. voltage low fault:** When the battery voltage is lower than this value and after the "Discharge Stop Delay Time" elapses, the inverter will report a low battery voltage fault and stop discharging.
- **Batt. volt. low delay:** Battery stop discharge delay time.
- **Batt. max. curr. dischg.:** Set the max. battery discharger current.

The following settings are only effective in hybrid grid operation mode:

- **Batt. volt. stop dischg. in hybrid:** Discharging stops when the battery voltage is lower than this value. (Effective when BMS communication is not established or fails.)
- **Batt. SOC stop dischg. in hybrid:** Discharging stops when the battery SOC is lower than this value. (Effective when BMS communication is normal.)
- **Batt. volt. restart dischg. :** The inverter stops discharging after low battery voltage, and resumes discharging when the battery voltage rises above this value. (Effective when BMS communication is not established or fails.)
- **Batt. SOC restart dischg.:** The inverter stops discharging after low battery capacity, and resumes discharging when the battery SOC rises above this value. (Effective when BMS communication is normal.)

Note: When the [Advanced Setup] - [Generator] - [Dry Contact Function] is set to Generator Control, the dry contact signal will activate when the discharge level falls below the hybrid network discharge limit, and the signal will be deactivated when the recharge threshold is exceeded.

5.2.4 Grid Connection Setup

5.2.4.1 Basic Page

- **Grid frequency:** Select the local grid frequency (50Hz/60Hz).
- **Sell Power Max.:** Set the maximum power for feeding into the grid.
- **Buy Power Max.:** Maximum power drawn from the grid. If the grid charging power + load power by the grid exceeds this setting, the inverter will prioritize reducing the grid charging power to avoid exceeding the buying power threshold.

- **Mains Peak Shaving:** When this function is enabled, the grid purchasing power will be limited to the set value. If the sum of grid purchasing power, PV generation power and battery power cannot meet the load power consumption after peak shaving, the grid peak shaving function will be invalid, and the grid purchasing power will exceed the set value.
- **zero-export power:** Error calibration power for anti-backflow, recommended to be set between 20-100W. Due to sampling accuracy issues, in order to bring the anti-backflow side power close to 0W:
 - ① When buying power $P > 0$, set this value to P ;
 - ② When selling power $P > 0$, set this value to $-P$.
- **On Grid Reactive Power:** Setting range 0~100%, % of reactive power.
- **Reactive power over/under excited:** "over" indicates 0%-100% / "under" indicates -100% ~ 0%.
- **On Grid PF:** Setting range 0.8 ~ 1.
- **Reactive power over / under excited:** "over" indicates 0.8 ~ 1 / "under" indicates -0.8 ~ -1

- **Grid standard (The actual display on the screen shall prevail):**

Austria: TE-OVE	Thailand: PEA-MEA PEA-MEA	Italy: CEI 0-21:2022/V1:2022
Germany: VDE-AR-N 4105:2018	Europe: EN 50549-1	Spain: UNE 217002: 2020-10
United States: IEEE Std 1547 2018/IEEE1547	Great Britain: G99	South Africa: NRS097
Australia: AS4777.2 Australia A	Myanmar	Poland: EN 50549-1
Australia: AS4777.2 New Zealand	Puerto Rico	Thailand: PEA-MEA
Ireland: EN50549-IE	United States: UL1741	Northern Ireland: G99/NI
Great Britain: G98	Northern Ireland: G98/NI	Uninitialized

5.2.4.2 Enter Service (User modification not recommended)

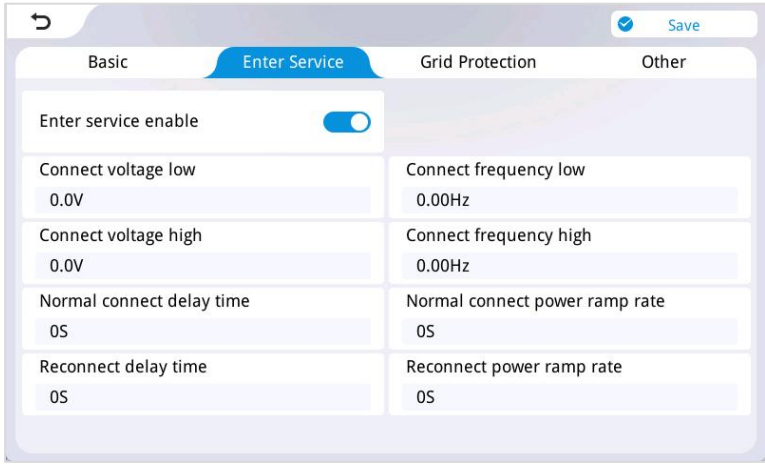

- **Enter service enable:** Grid connection startup setting (enabled by default).
- **Connect voltage low:** Min. voltage requirement for grid connection.
- **Connect frequency low:** Min. frequency requirement for grid connection.
- **Connect voltage high:** Max. voltage requirement for grid connection.
- **Connect frequency high:** Max. frequency requirement for grid connection.

- **Normal connect delay time:** The delay time for the inverter to connect to the grid when the grid first meets the connection requirements.
- **Normal connect power ramp rate:** The ramp rate of grid-connected power for the first grid connection.
- **Reconnect delay time:** Grid disconnection and reconnection, grid connection delay time.
- **Reconnect power ramp Rate:** Grid disconnection reconnection, rate of rise of grid-connected power.

5.2.4.3 Grid Protection (User modification not recommended)

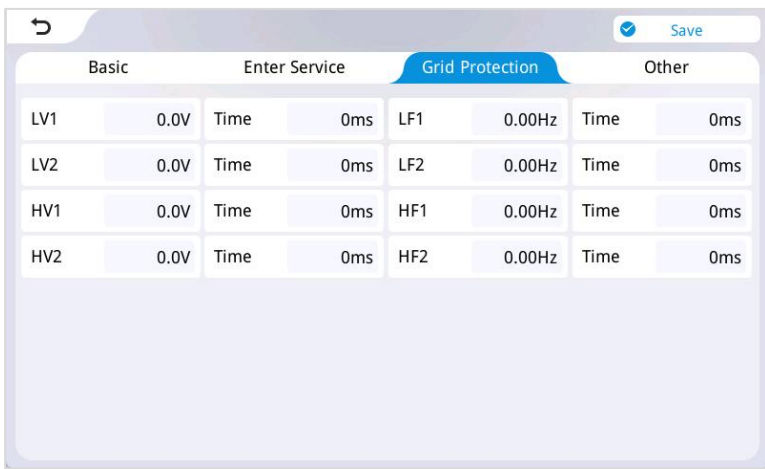

LV1	0.0V	Time	0ms	LF1	0.00Hz	Time	0ms
LV2	0.0V	Time	0ms	LF2	0.00Hz	Time	0ms
HV1	0.0V	Time	0ms	HF1	0.00Hz	Time	0ms
HV2	0.0V	Time	0ms	HF2	0.00Hz	Time	0ms

- **Time:** Time Protection Response Time.
- **LV1:** Class 1 undervoltage protection point. When the grid voltage drops below this threshold and remains so for the corresponding protection response time, the inverter shall disconnect from the grid.

- **LF1:** Class 1 underfrequency protection point. When the grid frequency drops below this threshold and remains below it for the corresponding protection response time, the inverter shall disconnect from the grid.
- **LV2:** Class 2 undervoltage protection point. When the grid voltage drops below this threshold and remains below it for the corresponding protection response time, the inverter shall initiate grid disconnection.
- **LF2:** Class 2 underfrequency protection point. When the grid frequency drops below this threshold and remains below it for the corresponding protection response time, the inverter shall disconnect from the grid.
- **HV1:** Class 1 overvoltage protection point. When the grid voltage rises above this threshold and remains above it for the corresponding protection response time, the inverter shall disconnect from the grid.

- **HF1:** Class 1 overfrequency protection point.
When the grid frequency exceeds this threshold and remains above it for the corresponding protection response time, the inverter shall disconnect from the grid.
- **HV2:** Class 2 overvoltage protection point.
When the grid voltage exceeds this threshold and persists above it for the preconfigured protection response time, the inverter shall initiate grid disconnection.
- **HF2:** Class 2 overfrequency protection point.
When the grid frequency exceeds this threshold and remains above it for the specified protection response time, the inverter shall disconnect from the grid.

5.2.4.4 Other Page (User modification not recommended)

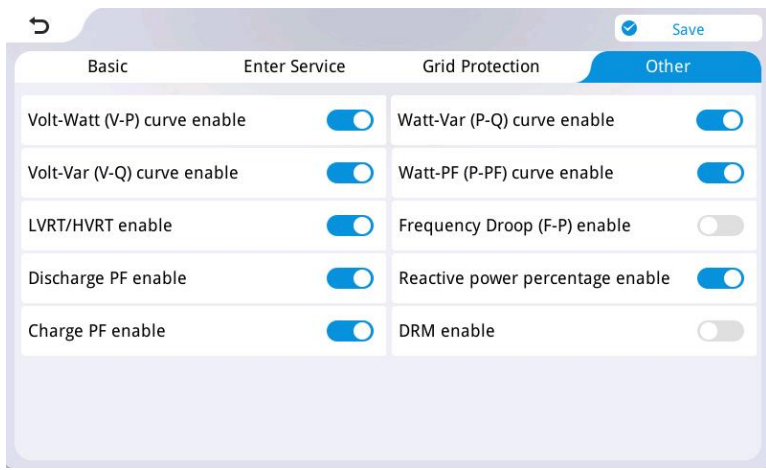

Basic	Enter Service	Grid Protection	Other
Volt-Watt (V-P) curve enable	<input checked="" type="checkbox"/>	Watt-Var (P-Q) curve enable	<input checked="" type="checkbox"/>
Volt-Var (V-Q) curve enable	<input checked="" type="checkbox"/>	Watt-PF (P-PF) curve enable	<input checked="" type="checkbox"/>
LVRT/HVRT enable	<input checked="" type="checkbox"/>	Frequency Droop (F-P) enable	<input type="checkbox"/>
Discharge PF enable	<input checked="" type="checkbox"/>	Reactive power percentage enable	<input checked="" type="checkbox"/>
Charge PF enable	<input checked="" type="checkbox"/>	DRM enable	<input type="checkbox"/>

- **Volt-Watt (V-P) curve enable:**
Regulates the active power of the inverter according to the set grid voltage.
- **Volt-Var (V-Q) curve enable:**
Adjustment of the inverter reactive power according to the set grid voltage.
- **LVRT/HVRT enable:**
Adjustment of the grid HV ride-through / LV ride-through values.

- **LFRT/HFRT enable:** According to the preset grid high-frequency/low-frequency ride-through thresholds.
- **Watt-Var (P-Q) curve enable:** Adjustment of the inverter reactive power according to the set active power.
- **Watt-PF (P-PF) curve enable:** Adjustment of the inverter power factor according to the set active power.
- **Frequency Droop (F-P) enable:** Adjustment of inverter output power according to grid frequency.
- **DRM Enable:** Australia only.

5.2.5 Advanced Setup

5.2.5.1 Generator

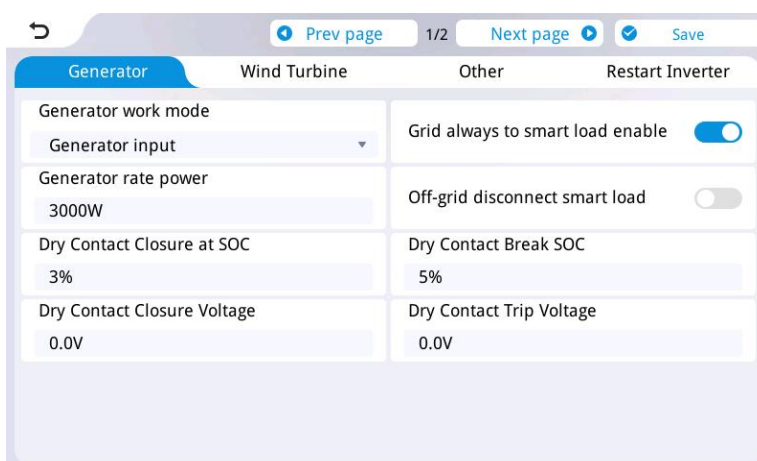

Generator	Wind Turbine	Other	Restart Inverter
Generator work mode		Grid always to smart load enable	<input checked="" type="checkbox"/>
Generator input		Off-grid disconnect smart load	<input type="checkbox"/>
Generator rate power	3000W	Dry Contact Closure at SOC	3%
Dry Contact Closure at SOC	3%	Dry Contact Break SOC	5%
Dry Contact Closure Voltage	0.0V	Dry Contact Trip Voltage	0.0V

- **Generator work mode:**
 - ① **Generator input:** When the generator is connected to the "Gen port", select the "Generator input".
 - ② **Micro inverter input:** When the on-grid inverter is connected to the "Gen Port" of the hybrid inverter, select the "Microinverter Input".
 - ③ **Smart load:** When the load is connected to the "Gen port", select "Smart load output".

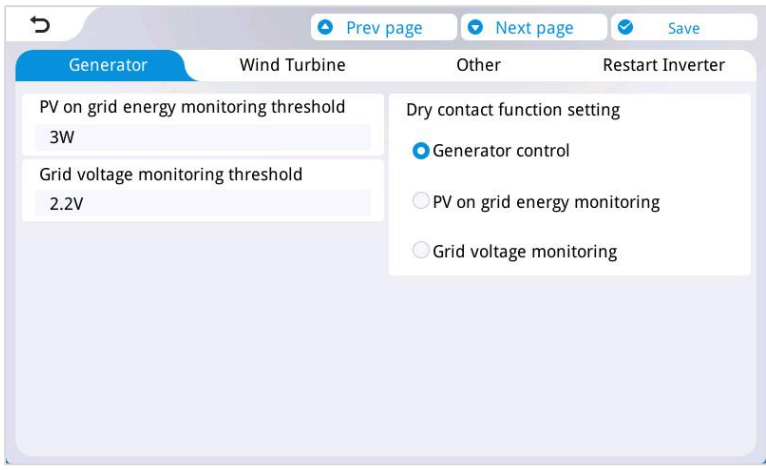

- **Grid always to smart load enable:** When the inverter operates in hybrid grid mode, the smart load shall always be enabled.
- **Generator rate power:** Setting the rated power of the generator.
- **Off-grid disconnect smart load:** When the inverter operates in off-grid mode, the smart load shall be immediately disabled.

- **Dry Contact Closure at SOC:** In off-grid mode, the normally open contact will close and the diesel generator will start when the battery SOC is below this value. (Valid when BMS communication is normal)
- **Dry Contact Break SOC:** In diesel generator mode, the normally open contact will open and the diesel generator will shut down when the battery SOC is above this value. (Valid when BMS communication is normal)
- **Turn on the smart load SOC:** When battery SOC > this value, enable smart load. (Effective when BMS communication is normal)
- **Turn off the smart load SOC:** When battery SOC < this value, disable smart load. (Effective when BMS communication is normal).
- **Dry contact function setting:**
 - ① Generator control.
 - ② PV on grid energy monitoring.
 - ③ Grid voltage monitoring.
- **PV on grid energy monitoring threshold:** When the PV grid-connected energy exceeds the threshold, the dry contact operates.
- **Grid voltage monitoring threshold:** When the grid voltage exceeds the threshold, the dry contact operates.

5.2.5.2 Wind Turbine

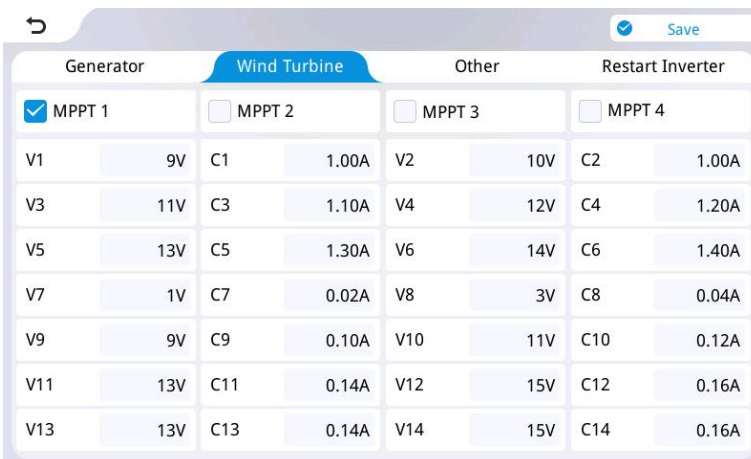

- **MPPT1/2/3/4:** Enable for wind turbine input.
- **V1/2/3/4.../14:** Voltage parameters for the wind turbine.
- **C1/2/3/4.../14:** Current parameters for the wind turbine.

5.2.5.3 Other Page

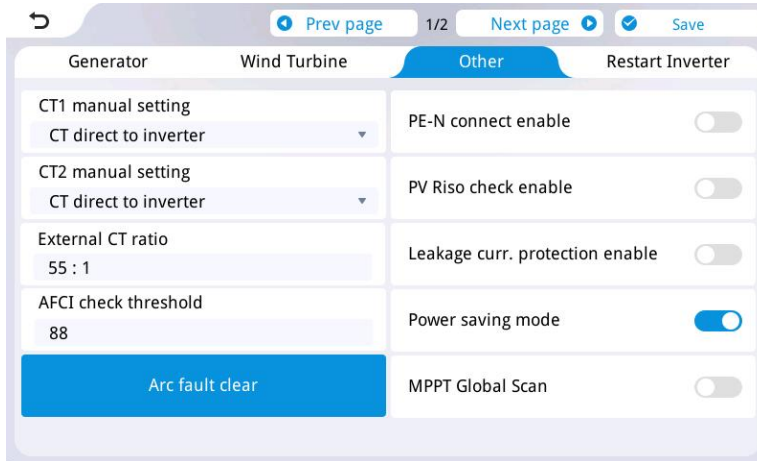
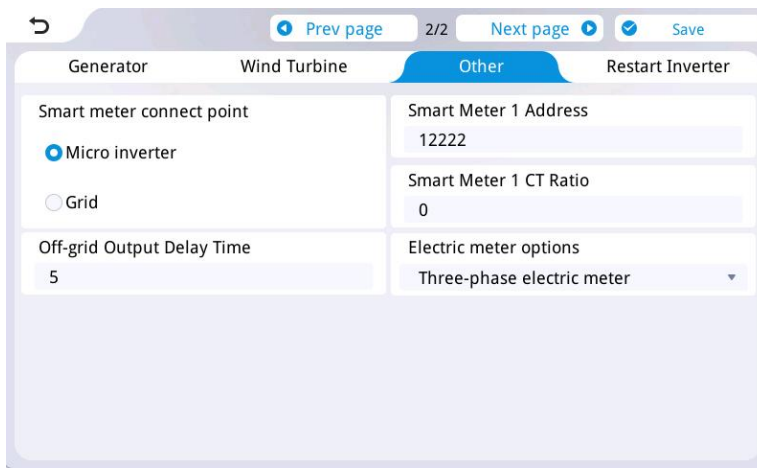
- **CT manual setting:** Select the CT direction according to the CT installation (ensure that the direction of each phase CT is consistent).
 - ① When the arrow on the CT points to the inverter, set it to "CT direct to inverter".
 - ② When the arrow on the CT points to the grid, set it to "CT direct to grid".
 CT1 refers to the built-in CT setting of the hybrid grid inverter.
 CT2 refers to the CT setting on the side of the grid-tied inverter.
- **External CT ratio:** When connecting the external CT1, input the ratio specified on the CT1 specification label. (CT1 is fixed for grid-side power sampling).
- **AFCI check threshold :** AFCI sensitivity setting range: 0-100.
 0: AFCI disabled;
 1-100: AFCI enabled, with higher values indicating lower sensitivity.
- **Electric meter options:**
 Whether to enable three-phase meter.

- **PE-N connect enable:** The PE-N function is valid in off-grid mode. Select this option to ensure reliable grounding of the inverter casing; otherwise, the inverter casing will be live with electricity.
- **PV Riso check enable:** Enable PV insulation impedance detection.
- **Leakage curr. protection enable:** Enable leakage current protection.
- **Power saving mode:** When the energy-saving mode is activated:
 - ① If the load power is less than 25W, the inverter output will turn off after 5 min;
 - ② If the load power is greater than 40W, the inverter output will restart immediately.
- **MPPT Global Scan:** When this function is enabled: The inverter will perform an MPPT global scan every 30 min. During the scan, the photovoltaic power will drop to 0W and then reach the maximum power point.
Note: Applicable to scenarios where the photovoltaic panels cannot output maximum power due to shading or other reasons.
- **Smart meter connect point:** Select the corresponding object based on the power to be collected by the meter.
 - ① When the meter is required to collect micro-inverter power, select "Micro inverter" (valid only when the micro-inverter is connected to the grid side);
 - ② When the meter is required to collect grid power, select "Grid".
- **Off-grid Output Delay Time:** 10s. When the grid is disconnected, the inverter will output power after a 10-second delay.

5.2.5.4 Restart Inverter

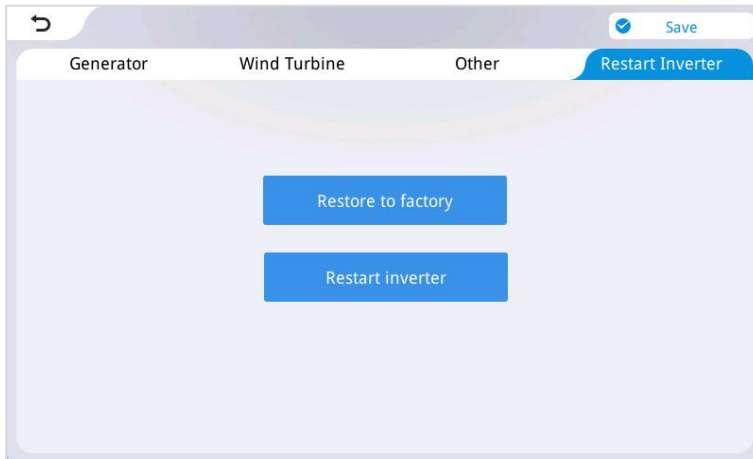

- **Restore to factory:** Reset all inverter settings.
- **Restart inverter:** Restart the inverter.

5.2.6 WiFi Setup

Important Note: In the current version, the WiFi function is only used for screen program upgrade.

5.2.6.1 Search and Select Network

Click the [**Refresh**] button, select the target network name from the hotspot list, and click to enter the password input interface.

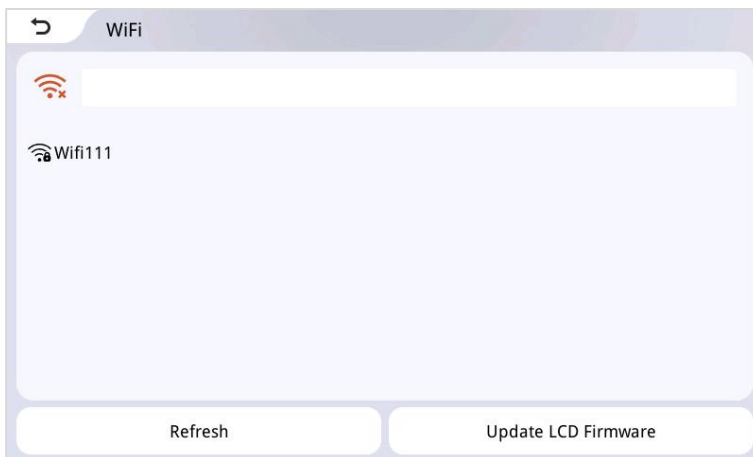

- **Refresh:** Refresh the WIFI network to obtain WIFI hotspots.
- **Update LCD Firmware:** Update the LCD display firmware.

5.2.6.2 Enter and Verify Password

Enter the WiFi network password (supporting numbers and letters) in the password input field; click [**Connect**] to confirm and establish the connection.

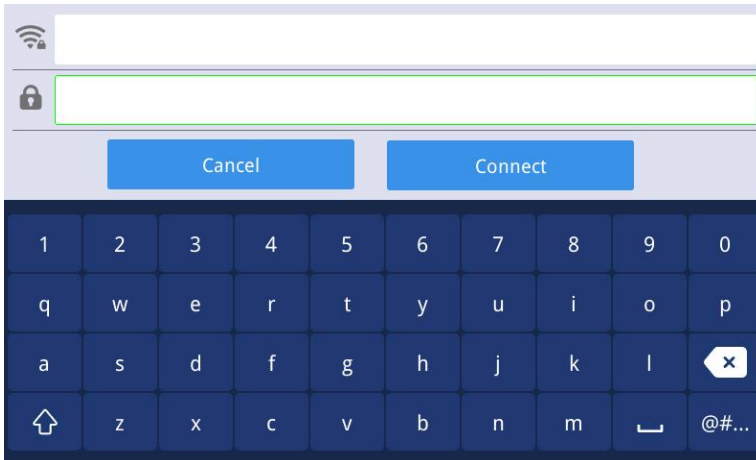

- **Cancel:** Exit the password data interface.
- **Connect:** Connect to the WIFI network.

5.2.7 Firmware Upgrade via USB Drive

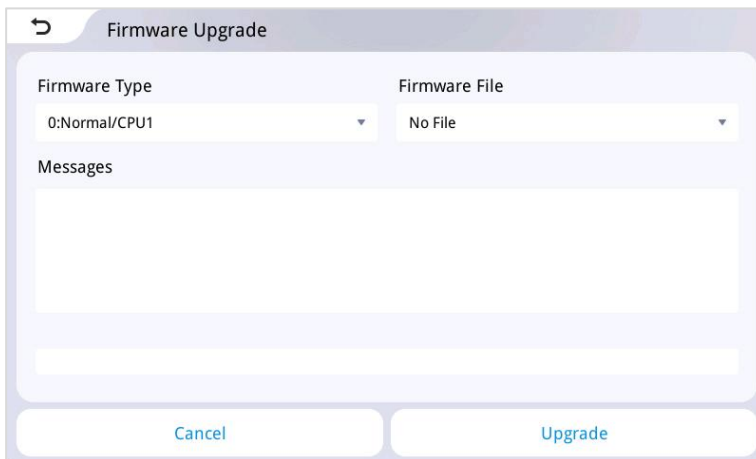

- **Firmware Type:**
 - ① Firmware type.
 - ② 0: Normal/CPU1
 - ③ 1: CPU2
 - ④ 2: AUX DSP
 - ⑤ 3: AFCI MCU
 - ⑥ 4: BMS MCU
- **Firmware File:** Firmware file in the USB drive.
- **Cancel:** Cancel the upgrade.
- **Upgrade:** Update the firmware.

5.3 Time-slot Charging/Discharging Function

The IESP SH3 series have the function of charging and discharging by different time periods. Users can set different charging and discharging time periods according to the local peak and valley electricity prices, so as to make rational use of the utility power and photovoltaic energy. When the utility power price is expensive, the battery inverter can be used to supply electricity to the load. When the utility power price is low, the utility power can be used to supply power to the load and charge the battery, which can help users save electricity bills to the greatest extent. The function of charging and discharging by different time periods, refer to Section 5.2.2.2.

Before using this function for the first time, please refer to Section 5.2.1.1 to set the local time. Users can set corresponding time periods according to the electricity prices during peak and off-peak hours in the local area.

Peak-Valley Electricity Tariff

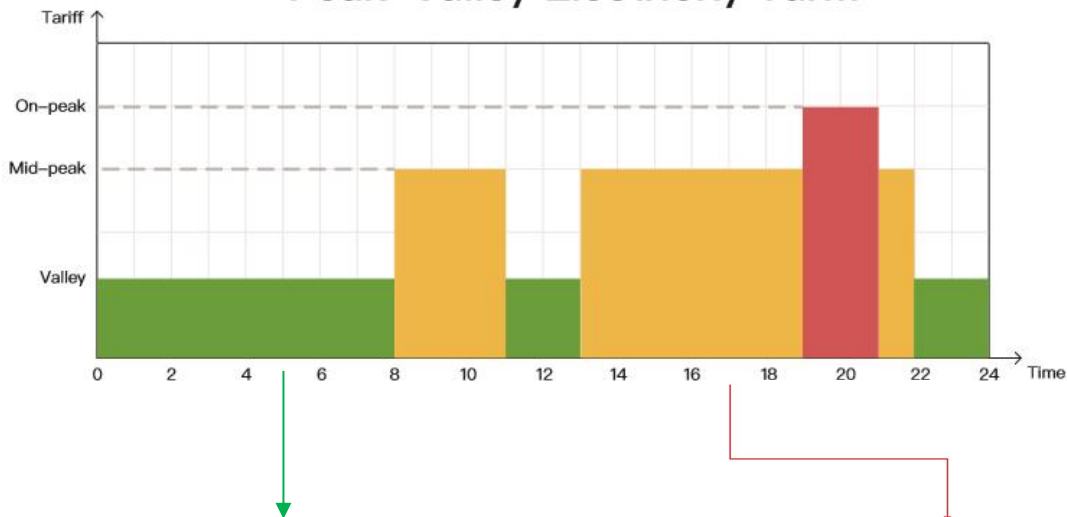

Time-slot Utility Charging & Loading Function



With 3 definable periods, the user can freely set the mains charging/supplying power time within the range of 00:00 to 23:59. During the time period set by the user, if PV energy is available, PV energy will be used first, and if PV energy is not available or insufficient, utility energy will be used as a supplement.

Time-slot Battery Discharging Function



With 3 definable time periods, users can freely set the battery discharge time within the range of 00:00 to 23:59. During the time set by the user, the inverter will give priority to the battery inverter to carry the load, and if the battery power is insufficient, the inverter will automatically switch to mains power to ensure stable operation of the load.

6. Communication

6.1 Product Overview

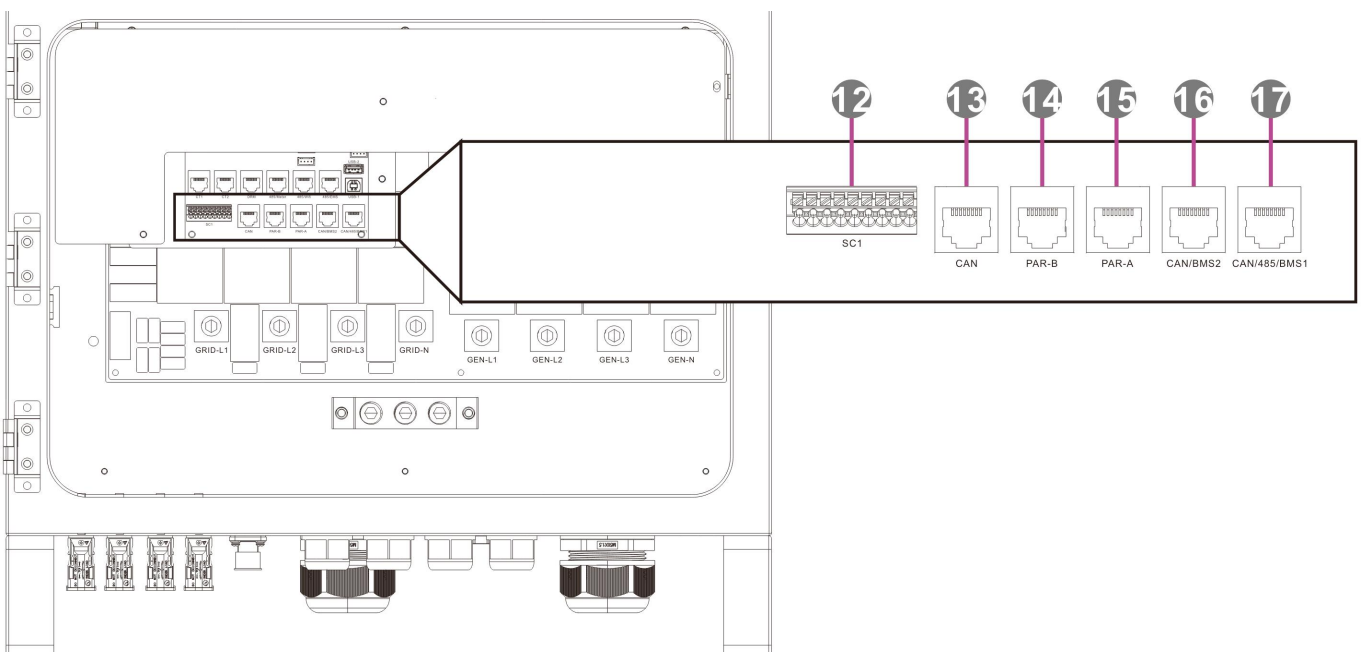
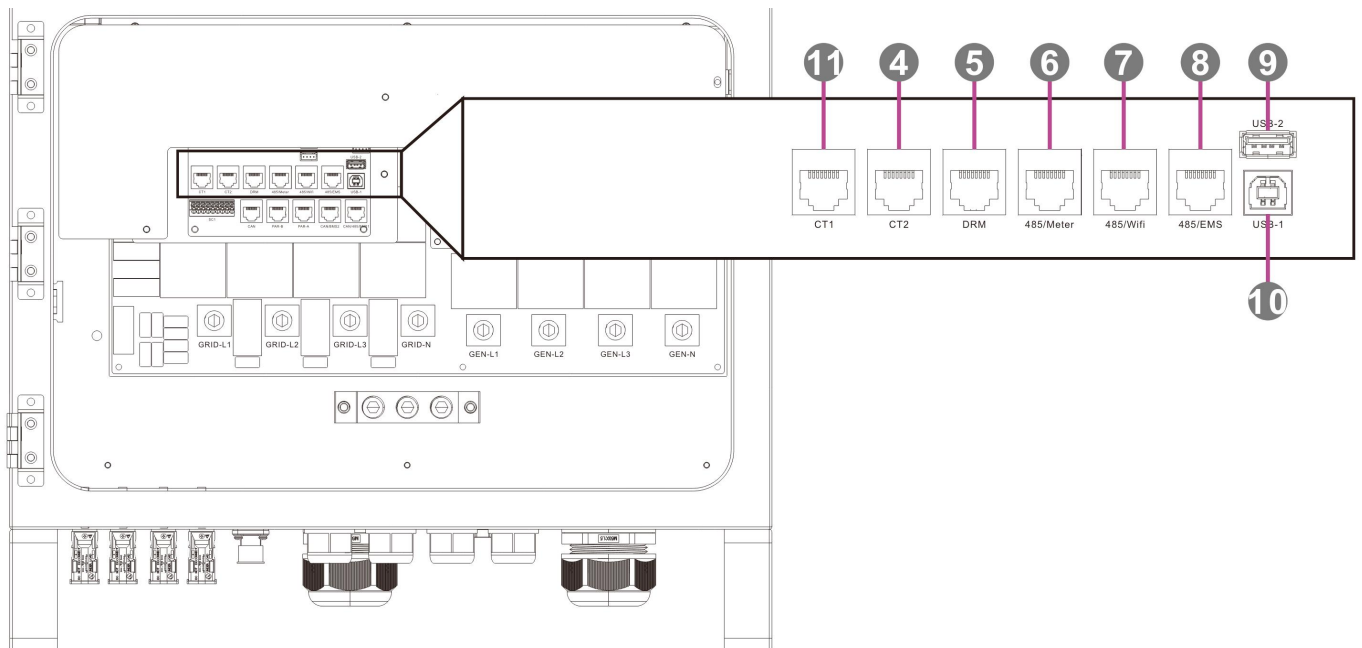

4	Micro-inverter CT2	5	DRM	6	485/Meter Port
7	485/WiFi Port	8	485/EMS Port	9	Display USB-2
10	Communication USB-1	11	Anti-backflow CT1 Prot	12	Dry Contact Interface
13	CAN2 Communication Port	14	Parallel Operation Port -B	15	Parallel Operation Port -A
16	CAN2/485/BMS2 Communication Port	17	CAN3/485/BMS1 Communication Port		

6.2 USB-1 Communication Port

The user can read and modify device parameters through this port by using the host software. Please contact us for the host software installation package if you require one.

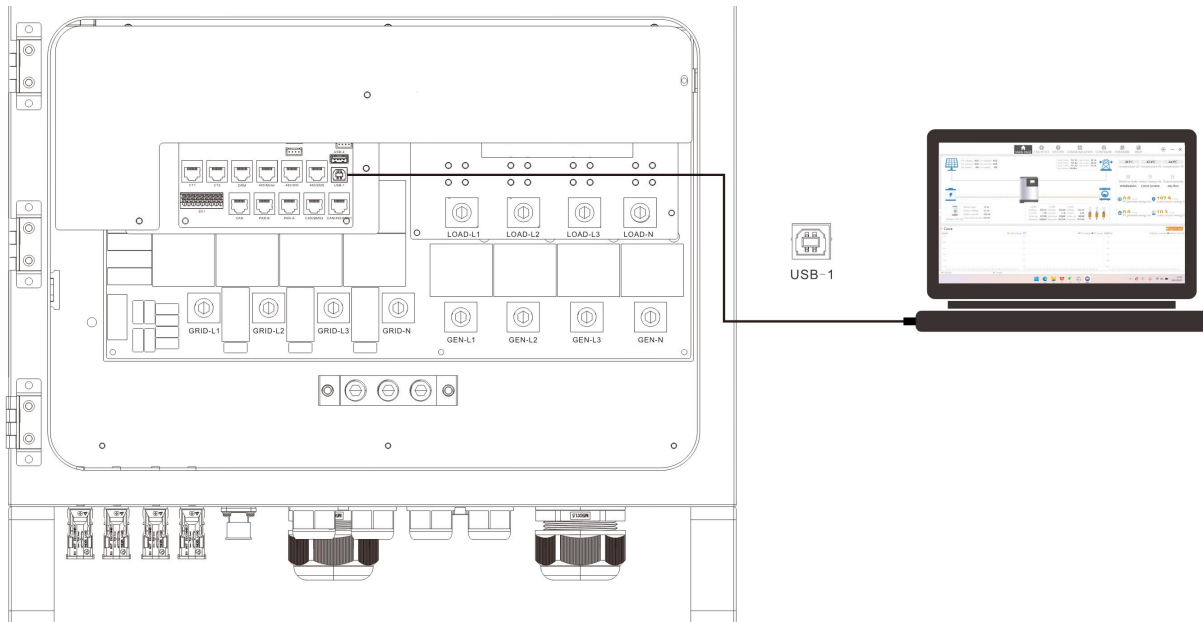

6.3 WiFi Communication Function

The WiFi port is used to connect to the Wi-Fi/GPRS logger module, which allows users to view the operating status and parameters of the inverter via mobile phone APP.

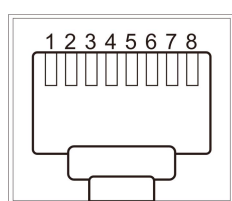
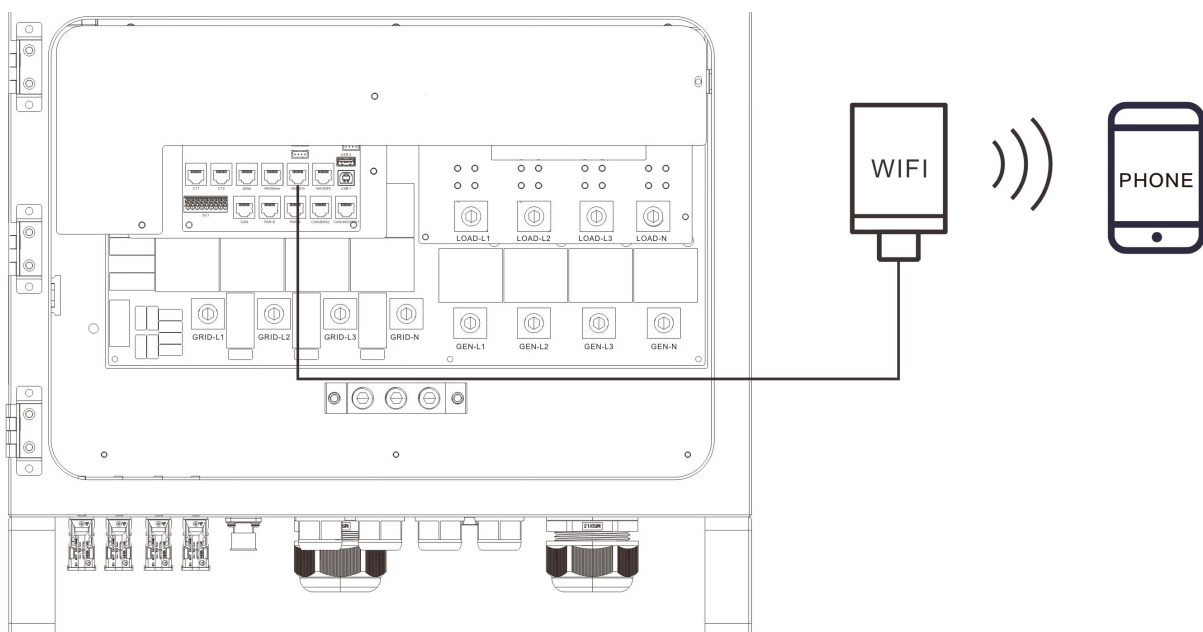

WIFI

RJ45	Pin 1	Pin 2	Pin 3	Pin 4	Pin 5	Pin 6	Pin 7	Pin 8
Definition	5V	GND	/	/	/	/	RS485-A	RS485-B

6.4 485/Meter Port

The 485/Meter port is used for connecting to the electricity meter for communication.

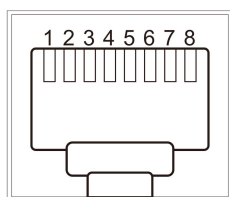

485/Meter

RJ45	Pin 1	Pin 2	Pin 3	Pin 4	Pin 5	Pin 6	Pin 7	Pin 8
Definition	RS485-B	RS485-A	/	/	/	/	RS485-A	RS485-B

6.5 485/EMS Port

The 485/EMS port is used for local user communication.

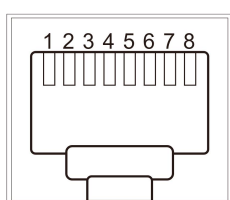

485/EMS

RJ45	Pin 1	Pin 2	Pin 3	Pin 4	Pin 5	Pin 6	Pin 7	Pin 8
Definition	RS485-B	RS485-A	/	/	/	/	RS485-A	RS485-B

6.6 CAN/485/BMS1/BMS2 Communication Ports

The CAN/485/BMS1/BMS2 ports are used to connect the lithium-ion battery's BMS.

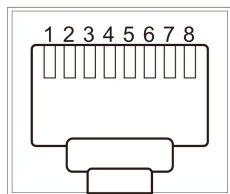

CAN/485/BMS

RJ45	Pin 1	Pin 2	Pin 3	Pin 4	Pin 5	Pin 6	Pin 7	Pin 8
Definition	RS485-B	RS485-A	/	CANH	CANL	/	RS485-A	RS485-B

NOTICE

If you need to use the inverter to communicate with the lithium battery BMS, please contact us for the communication protocol or upgrade the inverter to the appropriate software programme.

6.7 USB-2 Display Port

It is used to updated the screen firmware.

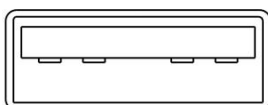

6.8 DRM(Only Australia)

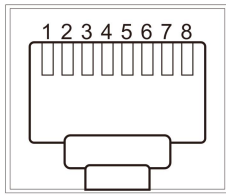

DRM

RJ45	Pin 1	Pin 2	Pin 3	Pin 4	Pin 5	Pin 6	Pin 7	Pin 8
Definition	DRM5	DRM6	DRM7	DRM8	RefGen	COM/ DRM0	V+	V-

MODEL	RJ45 socket asserted by shorting pins		Requirement
DRM0	5	6	Operate the disconnection device.
DRM5	1	5	Do not generate power to grid.
DRM6	2	5	Do not generate at more than 50% of rated power.
DRM7	3	5	Do not generate at more than 75% of rated power AND Sink reactive power if capable.
DRM8	4	5	Increase power generation (subject to constraints from other active DRM) .

6.9 External CT Prot

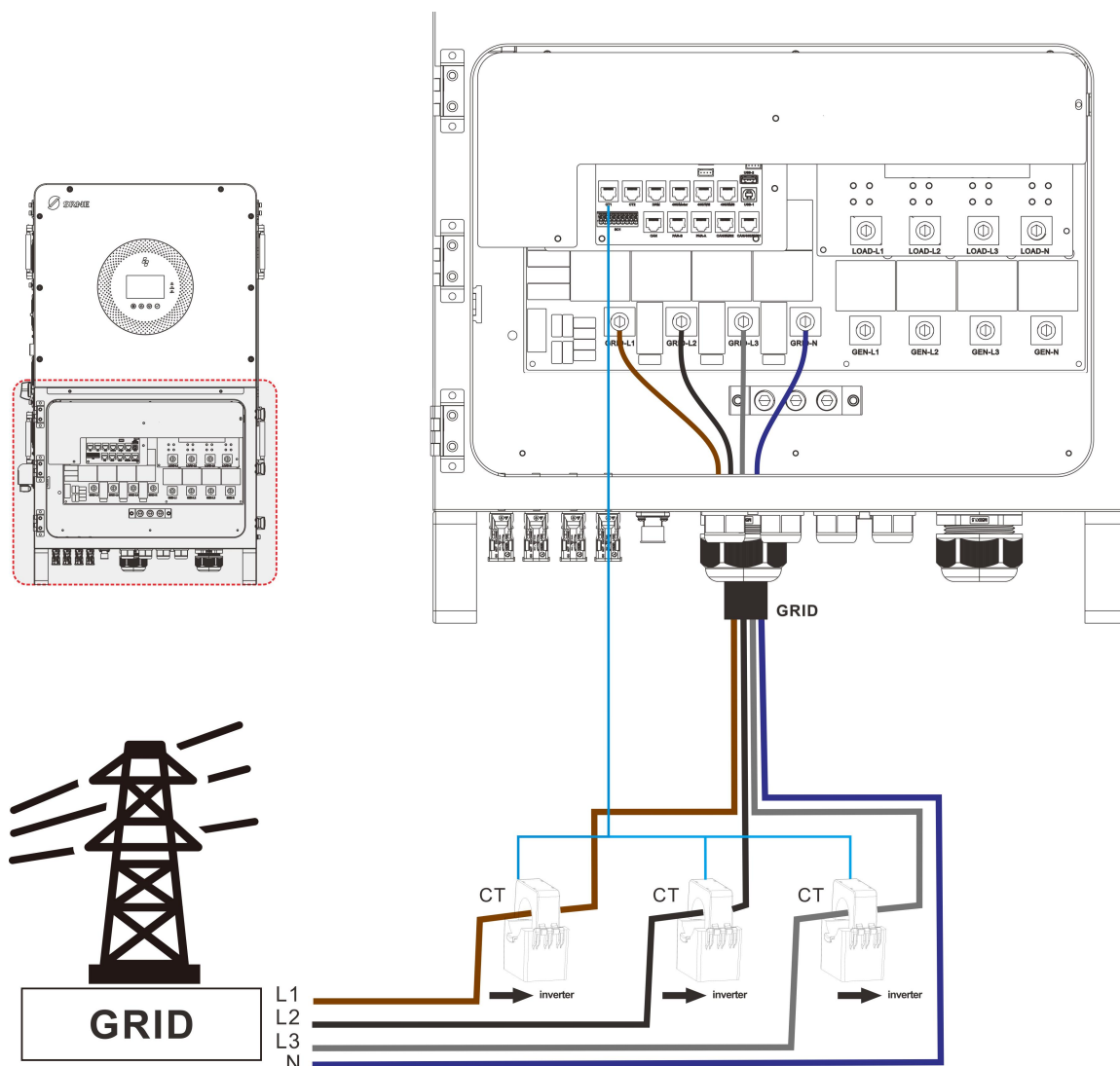

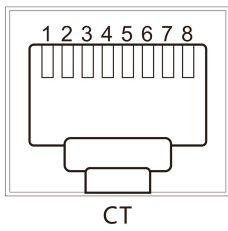

RJ45	Pin 1	Pin 2	Pin 3	Pin 4	Pin 5	Pin 6	Pin 7	Pin 8
Definition	CT1+	CT1-	/	CT2+	CT2-	/	CT3+	CT3-

1. Split-core current transformer (CT) dimensions (mm)
2. Secondary output cable length is 3 meters.

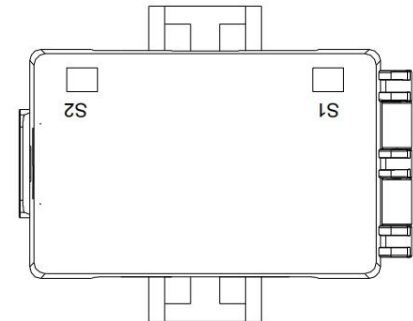
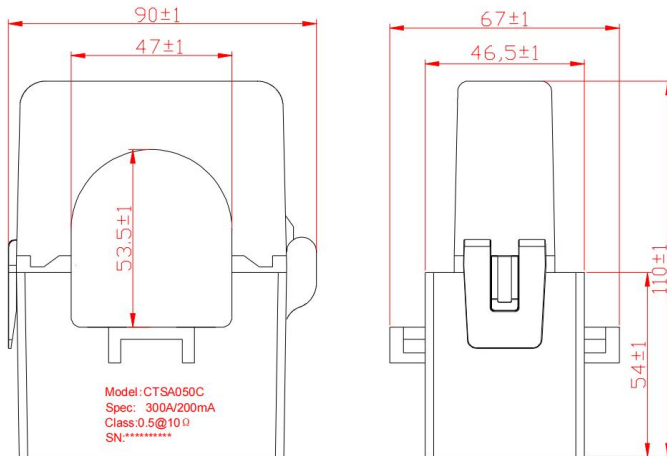

6.10 Dry Contact Function

The dry contact port has 5 functions:

- ① Generator remote start/stop;
- ② Temperature sampling (reserved);
- ③ RSD power supply;
- ④ Remote signal transmission;
- ⑤ Remote signal reception.

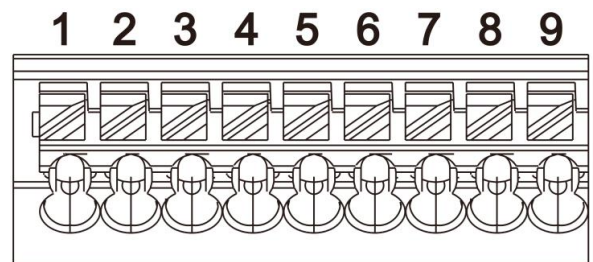

Function	Definition
Generator remote start/stop	1-2: NO; 1-3: NC Remote generator shutdown: Pins 1 to 2 are normally opened; pins 1 to 3 are normally closed. (Pins 1/2/3 output 125Vac/1A, 230Vac/1A, 30Vdc/1A).
Temperature sampling (reserved)	Pins 9 and 5 can be used for battery temperature sampling compensation.
RSD power supply	Pin 9 is GND, pin 4 is RSD 12V+.
Remote signal transmission	Pins 9 and 7/8: DSP internal signal transmission.
Remote signal reception	Pins 9 and 6: DSP internal signal reception.

NOTICE

If you need to use the remote start/stop function of the generator with dry contact, ensure that the generator has ATS and supports remote start/stop.

6.11 DIP Switch Configuration



This DIP switch is a resistor matching switch for parallel communication. When performing parallel CAN communication, the first and last units in the parallel system must have DIP switches 1 and 2 set to the up position.

6.12 Remote Monitoring

When operating the equipment, it is recommended to enable a remote monitoring configuration.

The inverter supports APP application to provide more comprehensive and intuitive monitoring of power plant data, creating the ultimate user experience with extremely simplified product design thinking to meet the convenient operation of offline applications.

6.12.1 Download App

- **App Download:** Android system can search "SOLARMAN Smart" through application market/store for downloading, while IOS system can choose to download SOLARMAN Smart APP in Apple Store.
- **QR code download:** SOLARMAN Smart APP can also support scanning QR code with mobile phone for downloading. Please scan the code with mobile phone.



6.12.2 Stick Logger Installation

Step2: Connect inverter with data logger, and tighten it.

The normal operation status of the stick logger, when router connected to the network normally:

- ① Connection to the server succeeded: NET light keeps on after the logger powered on.
- ② Logger running normally: READY light flashes.
- ③ Connection to the inverter succeeded: COM light keeps on.

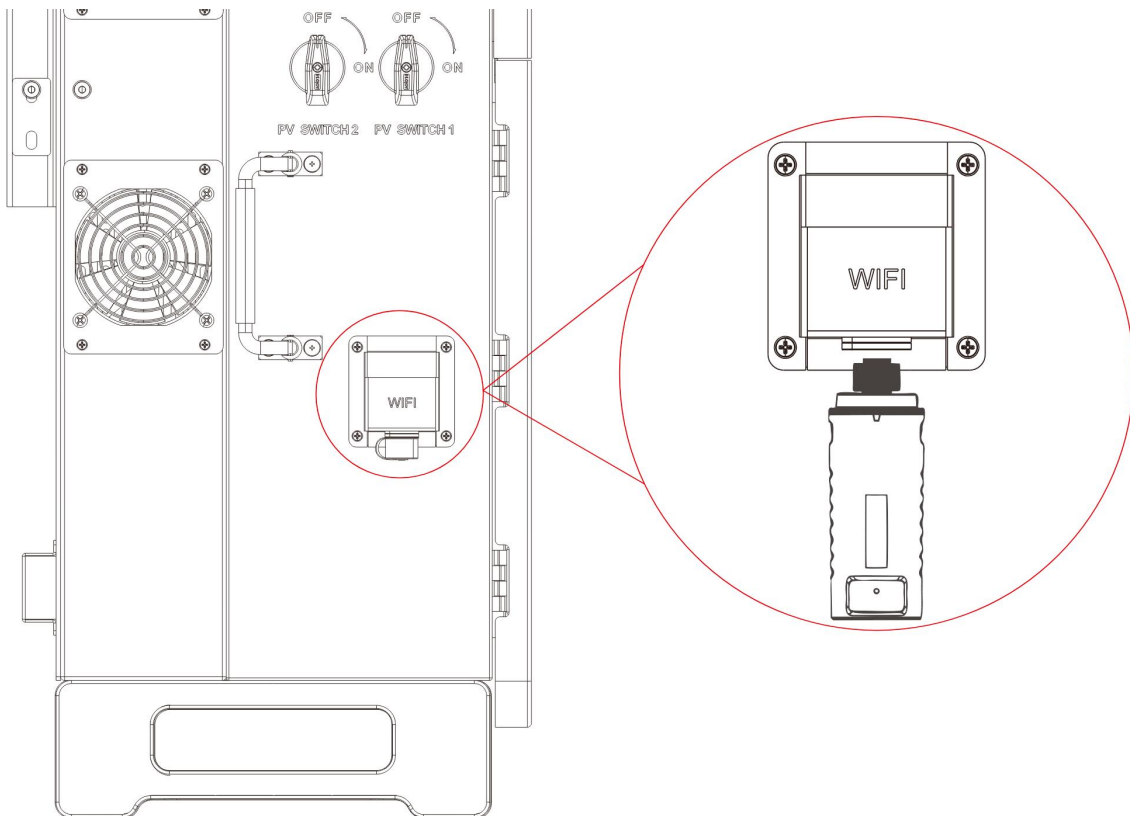

6.12.3 SOLARMAN Smart APP Operation

Please make sure Bluetooth and WiFi are ON and the router can connect to the network normally.

■ Registration

Go to SOLARMAN Smart and register.

Click "Register" and create an account here.

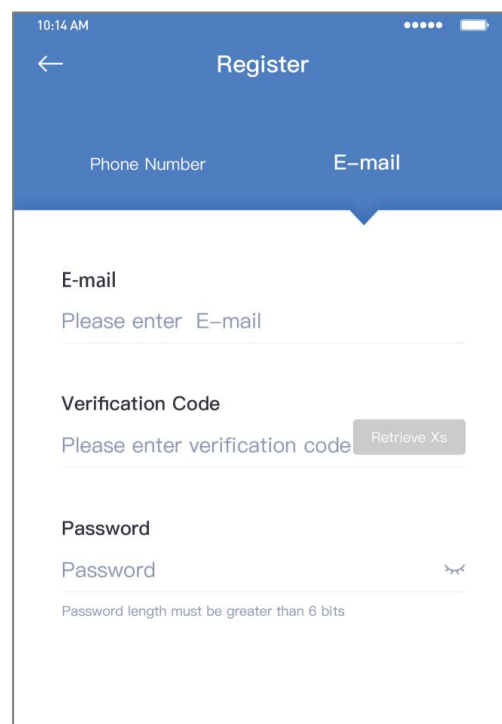
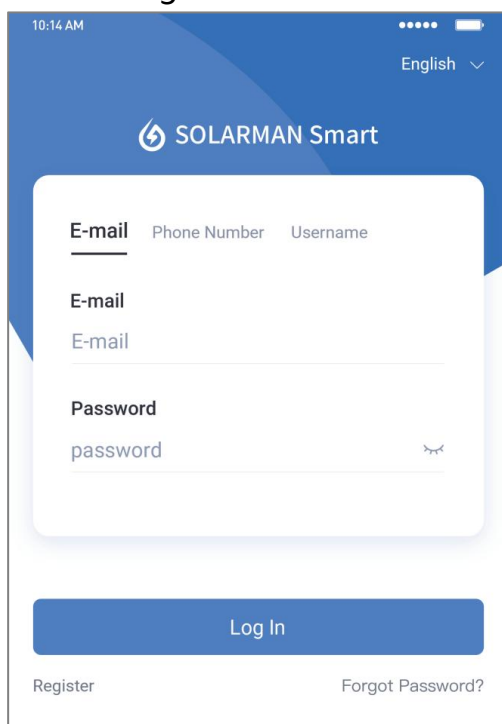

■ Create a Plant

Click "Add Now" to create your plant.

Please fill in plant basic info and other info here.

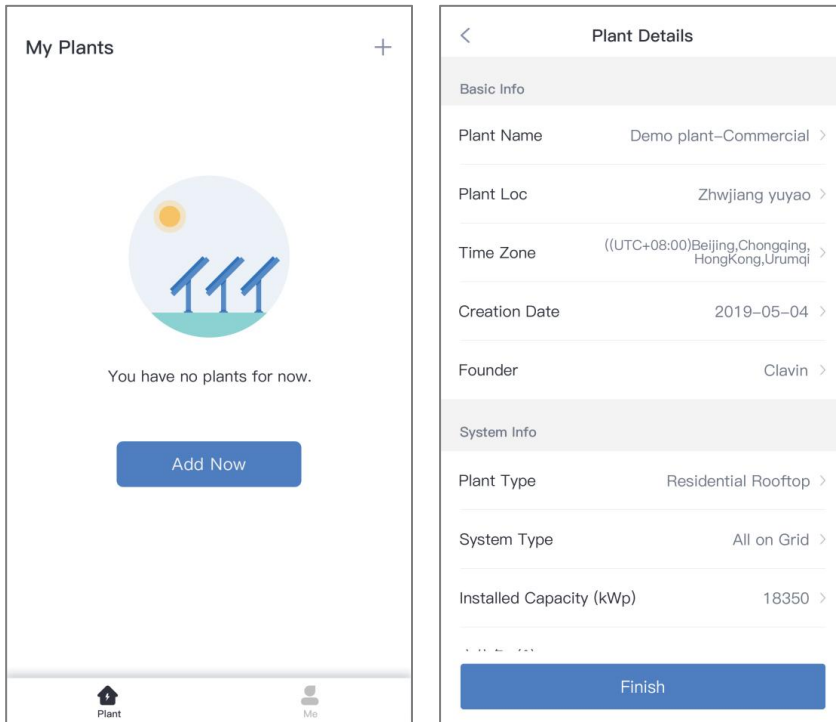

■ Add a Logger

Method 1: Enter logger SN manually.

Method 2: Click the icon in the right and scan to enter logger SN

You can find logger SN in the external packaging or on the logger body

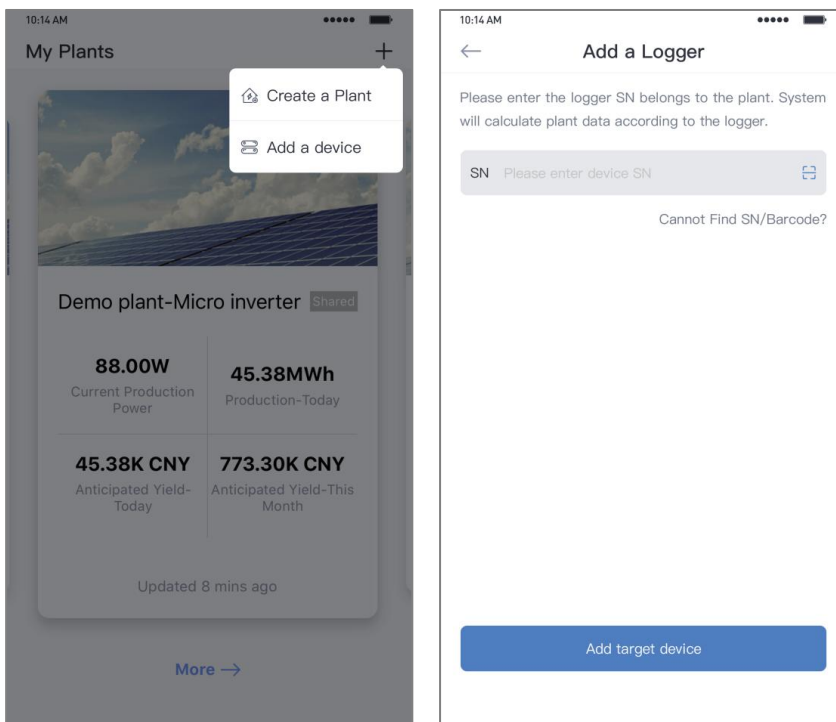

■ Network Configuration

Step 1: Click "Go to Configure" to set the network. (Please make sure Bluetooth and WiFi are ON.)

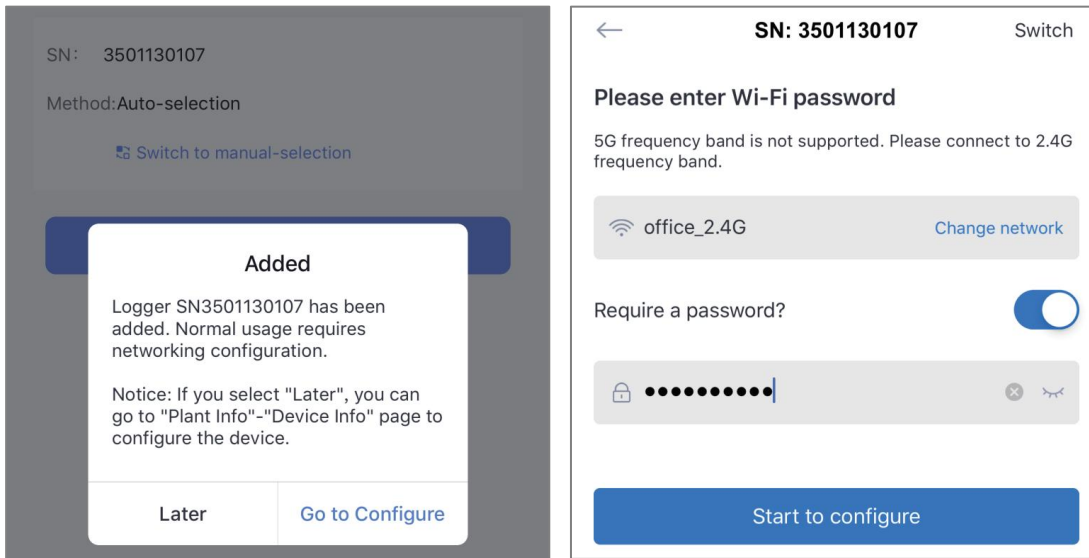

Step 2: Please wait for a few minute. Then click "Done" and view plant data.

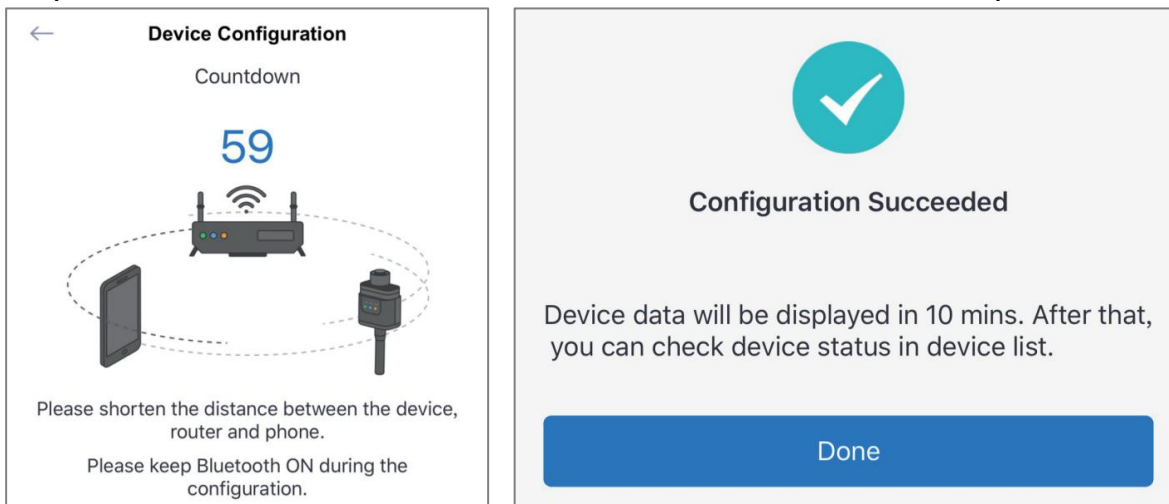

NOTICE

If configuration failure occurs, please check the following reason and try it again.

- Make sure WLAN is ON.
- Make sure WiFi is normal.
- Make sure wireless router does not implement the white-black list.
- Remove the special characters in Wi-Fi network.
- Shorten the distance between the phone and device.
- Try to connect to other Wi-Fi.

6.12.4 Plant Detail



After the photovoltaic plant is created and connected to the Logger, you can select the plant to view the corresponding plant data and related settings, including Real time, Statistical, Device, Alerts, Plant Info and Layout, so as to meet the end user's maintenance of plant information and data browsing.

Note: In general, the Plant data can be viewed normally only after 5-10 minutes after the Logger networking configuration is completed.

■ Real-time Data

In the "Real time" interface, you can see the real-time data of the Plant, such as real-time generation power and output, energy flow chart, 24-hour power curve, generation and consumption data, etc. The system will display different page layouts according to your plant grid connection type. Please set your plant according to the actual situation. Depending on your equipment, we recommend:

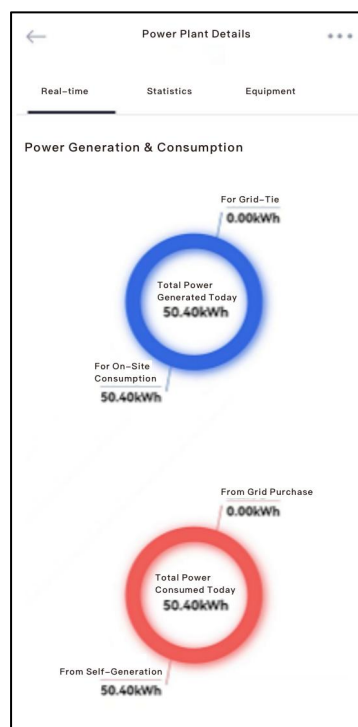
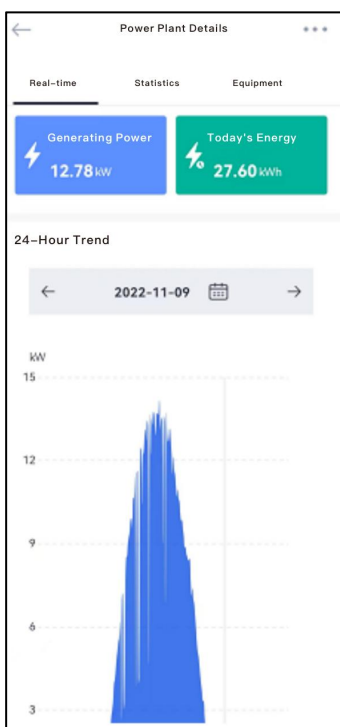

- ① If your equipment (such as inverter) only collects power generation data and transmits it to the grid company, it is recommended that you select "All on Grid" as the System Type of the Plant
- ② If your equipment (such as inverter) collects power generation data and power consumption data at the same time, it is recommended that you select "Self consumption" as the System Type of the Plant
- ③ If your equipment (such as inverter) collects power generation data, power consumption data, battery data and grid data at the same time, it is recommended that you select "Storage System" as the System Type of the Plant.

■ Device info

In the "Device" interface, you can view the device information under plant. Select and click a specific device to view the specific information of the device, including the device parameters, data statistics and connection information.

Through these data, you can determine whether the device is in normal working state. It can support networking configuration, meter configuration and other functional operations for the corresponding equipment. If the equipment is a logger, networking configuration can be carried out. If the equipment is an electricity meter, meter configuration can be carried out.

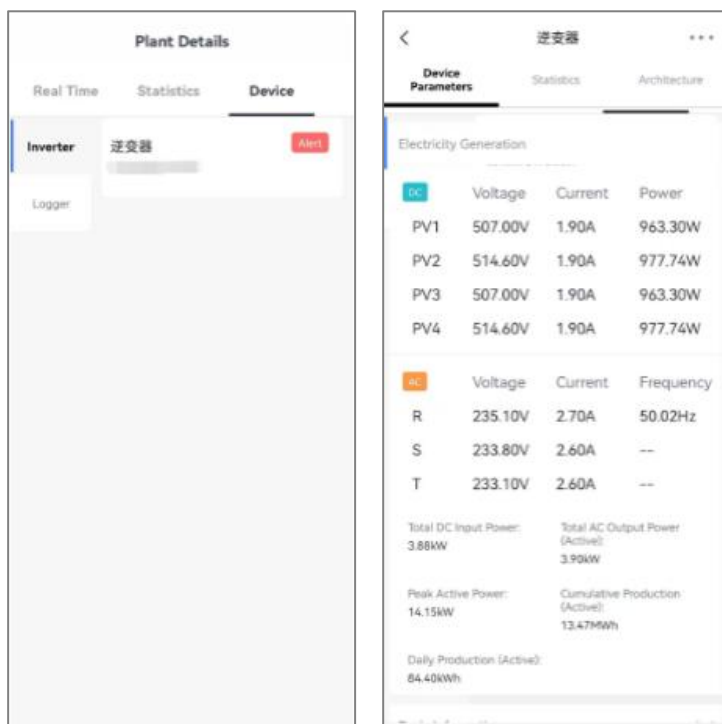

6.12.5 Abnormal State Processing

If the data on platform is abnormal when the stick logger is running, please check the table below and according to the status of indicator lights to complete a simple troubleshooting. If it still can not be resolved or indicator lights status do not show in the table below, please contact Customer Support.

(Note: Please using the following table query after power-on for 2mins at least.)

NET ● NET	COM ● COM	READY ● READY	Fault Description	Fault Cause	Solution
Any state	OFF	Slow flash	Communicate with inverter abnormally	1.Connection between stick logger and inverter loosen. 2.Inverter does not match with stick logger's communication rate.	1.Check the connection between stick logger and inverter. Remove the stick logger and install again. 2.Check inverter's communication rate to see if it matches with stick logger's. 3.Long press Reset button for 5s, reboot stick logger.
OFF	ON	Slow flash	Connection between logger and router abnormal	1.Stick logger does not have a network. 2.Router WiFi signal strength weak.	1.Check if the wireless network configured. 2.Enhance router WiFi signal strength.
Slow flash	ON	Slow flash	Connection between logger and router normal, connection between logger and remote server abnormal.	1.Router networking abnormal. 2.The server point of logger is modified. 3.Network limitation, server cannot be connected.	1.Check if the router has access to the network. 2.Check the router's setting, if the connection is limited. 3.Contact our customer service.
OFF	OFF	OFF	Power supply abnormal	1.Connection between stick logger and inverter loosen or abnormal. 2.Inverter power insufficient. 3.Stick Logger abnormal.	1.Check the connection, remove the stick logger and install again. 2.Check inverter output power. 3.Contact our customer service.
Fast flash	Any state	Any state	Networking status	Normal	1.Exit automatically after 2mins. 2.Long press Reset button for 5s, reboot stick logger. 3.Long press Reset button for 10s, restore factory settings.
Any state	Any state	Fast flash	Restore factory settings	Normal	1.Exit automatically after 1mins. 2.Long press Reset button for 5s, reboot stick logger. 3.Long press Reset button for 10s, restore factory settings.

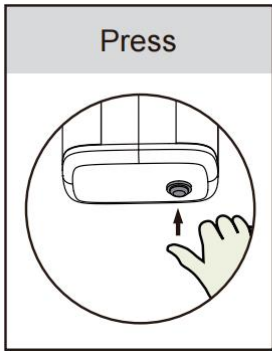

Key-press	Status Description	Light Status
Long press 5s then release	Rebooting the stick logger.	All lights are extinguished immediately.
Long press 10s then release	Resetting the stick logger.	1.All lights are extinguished after 4s. 2.READY light flashes fast for 100ms.

Warning:
Please do not hold the logger body to rotate while install or remove the logger.

Notice:
Do not remove waterproof plug.

7. Working Modes

■ Mode 1: Generator Mode

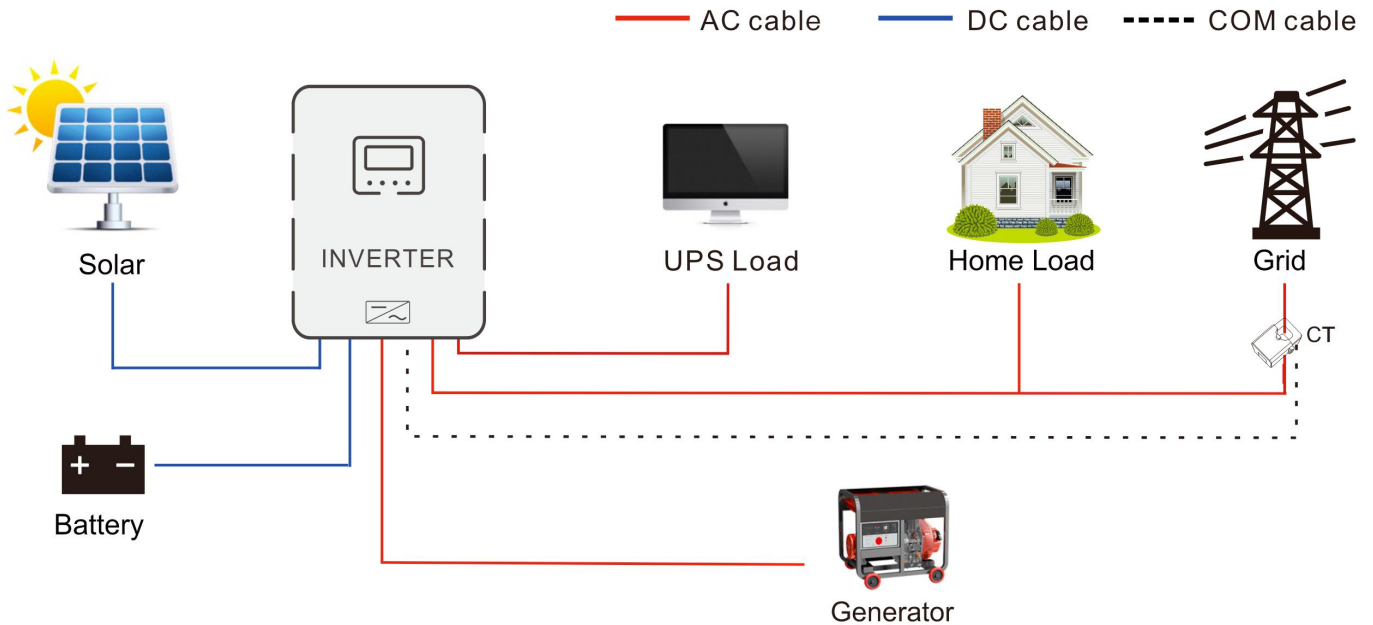

NOTICE

When the GEN port is configured as "Generator Input", the GRID port relay and GEN port relay will not close simultaneously. The generator will only be activated and the GEN port relay closed in Off-grid Mode.

■ Mode 2: Smart Load Mode

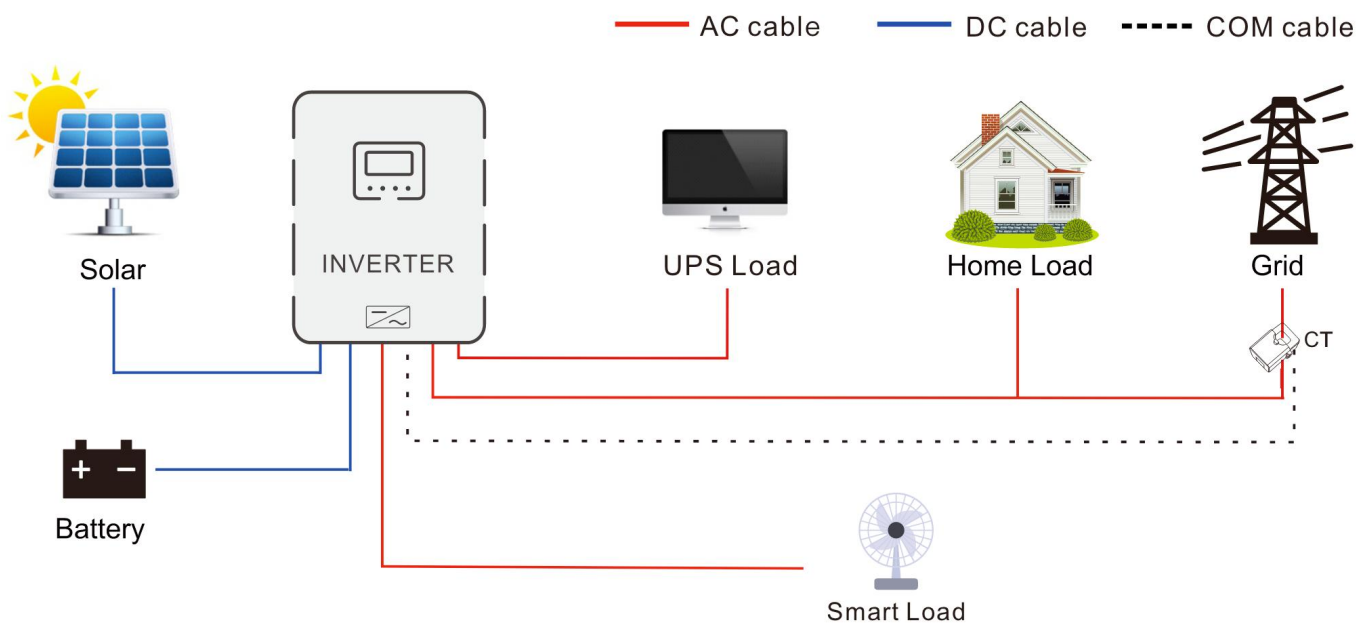

■ Mode 3: AC Coupling Mode I

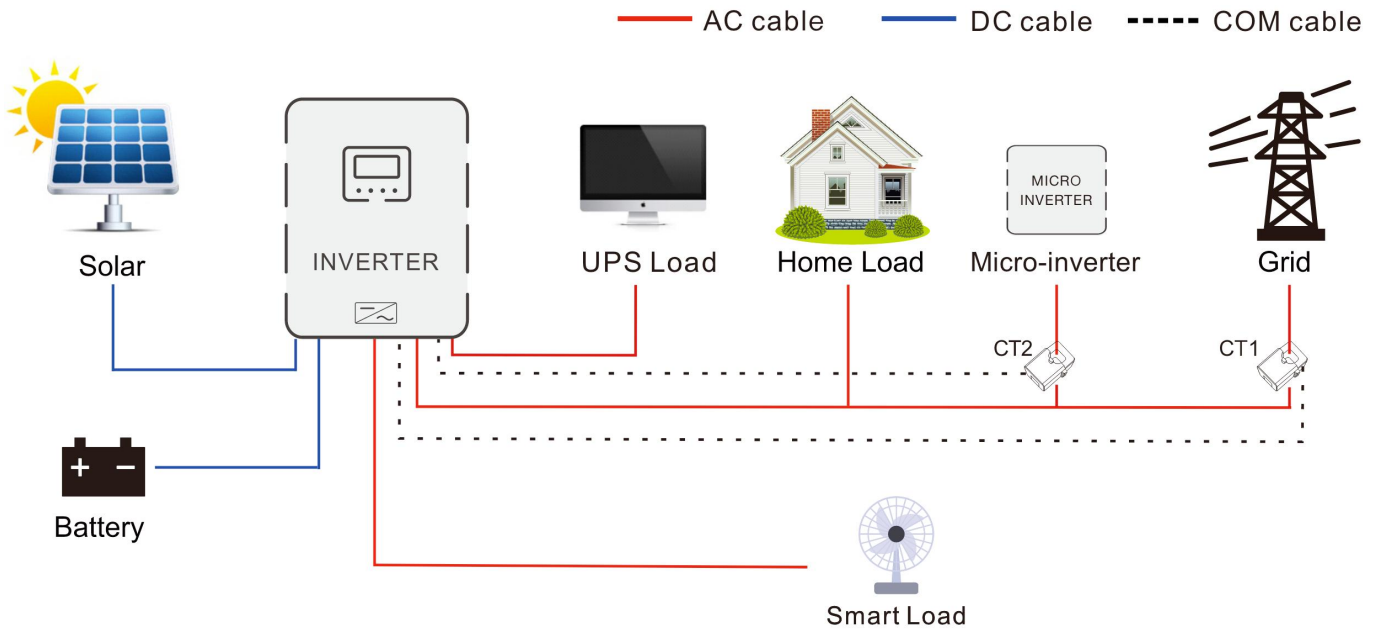

■ Mode 4: AC Coupling Mode II

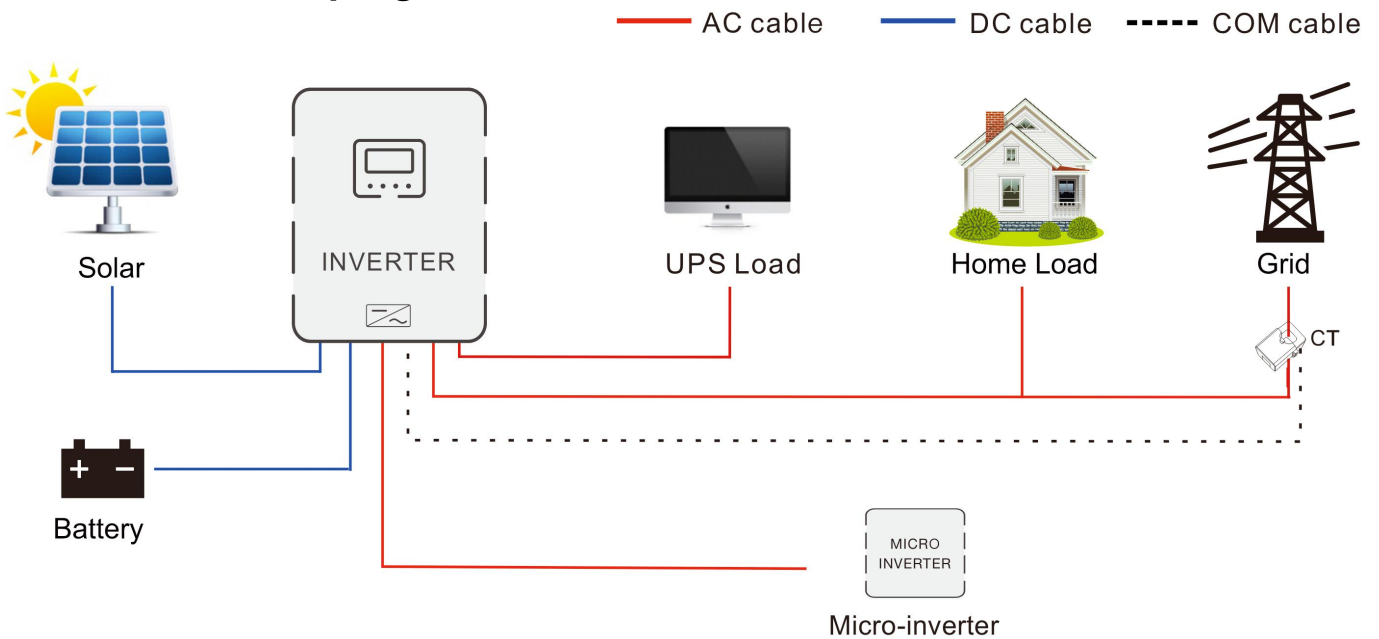

NOTICE

For the AC coupling mode, the inverter operating mode shall be set to AC Coupling. When a PV inverter is connected to the GEN port, the GEN port shall be set to Micro-inverter Input.

8. Fault and Remedy

8.1 Fault Codes

Fault Code	Fault name	Whether it affects the output or not	Description
01	BatVoltLow	NO	Battery undervoltage alarm.
02	BatOverCurrSw	YES	Battery discharge average current overcurrent (software protection).
03	BatOpen	YES	Battery not-connected alarm.
04	BatLowEod	YES	Battery undervoltage stop discharge alarm.
05	BatOverCurrHw	YES	Battery overcurrent (hardware protection).
06	BatOverVolt	YES	Charging overvoltage protection.
07	BusOverVoltHw	YES	Bus overvoltage (hardware protection).
08	BusOverVoltSw	YES	Bus overvoltage (software protection).
09	PvVoltHigh	NO	PV overvoltage protection.
10	PvBoostOCSw	YES	Boost overcurrent (software protection).
11	PvBoostOCHw	NO	Boost overcurrent (hardware protection).
12	SpiCommErr	YES	SPI communication fault of master and slave chips.
13	OverloadBypass	YES	Bypass overload protection.
14	Overload Inverter	YES	Inverter overload protection.
15	AcOverCurrHw	YES	Inverter overcurrent hardware protection.
16	AuxDspReqOffPWM	YES	Slave chip OFF request fault.
17	InvShort	YES	Inverter short-circuit protection.
18	Bussoftfailed	YES	Bus soft-start failure.
19	OverTemperTrans	YES	Overtemperature Protection for PV Heatsink.
20	OverTemperInv	YES	Overtemperature Protection for Inverter Heatsink
21	FanFail	YES	Fan failure.
22	EEPROM	YES	Memory failure.
23	Model NumErr	YES	Model setting error.
24	Busdiff	YES	Positive and negative bus voltage imbalance.
25	BusShort	YES	Bus short circuit.
26	Rlyshort	YES	Inverter AC output backfeed to bypass AC output.
27	LinePhaselose	YES	Grid input phase lose.
28	LinePhaseErr	YES	Grid input phase error.
29	BusVoltLow	YES	Low bus voltage protection.

30	BatCapacityLow1	NO	Alarm given when battery capacity rate is lower than 10% (setting BMS to enable validity).
31	BatCapacityLow2	NO	Alarm given when battery capacity rate is lower than 5% (setting BMS to enable validity).
32	BatCapacityLowStop	YES	Inverter stops when battery capacity is low (setting BMS to enable validity).
33	ControlCanFault	YES	Control CAN fault in parallel operation.
34	CanCommFault	YES	CAN communication fault in parallel operation.
35	ParaAddrErr	YES	Parallel ID (communication address) setting error.
36	Balance currentOC	YES	Balanced bridge arm overcurrent fault.
37	ParaShareCurrErr	YES	Parallel operation current sharing failure.
38	ParaBattVoltDiff	YES	Parallel mode, inconsistent utility input source.
39	ParaAcSrcDiff	YES	Parallel mode, inconsistent mains input source.
40	ParaHwSynErr	YES	Parallel mode, hardware synchronization signal failure.
41	InvDcVoltErr	YES	Abnormal DC component of inverter voltage
42	SysFwVersionDiff	YES	Inconsistent parallel operation program versions
43	ParaLineContErr	YES	Parallel operation wiring fault
44	Serial number error	YES	Serial number not set at factory
45	Error setting of split-phase mode	YES	Incorrect parallel operation mode settings
46	Electric meter communication failure	YES	Electric meter communication failure
49	Grid over voltage	YES	Set the local grid standard in the setup menu.
50	Grid under voltage	YES	
51	Grid over Frequency	YES	
52	Grid under Frequency	YES	
53	Grid loss	YES	
54	Grid DC current over	YES	
55	Grid standard un init	YES	
56	Low insulation resistance fault	NO	PV1+, PV2+, PV3+, PV4+, PV- impedance to ground abnormally low.
57	Leakage current overload fault	YES	System leakage current exceeds the standard.
58	BMSComErr	NO	BMS communication error.
60	BMSUnderTem	NO	BMS low temperature alarm (effective after successful BMS communication).
61	BMSOverTem	YES	BMS over-temperature alarm (effective after successful BMS communication).
62	BMSOverCur	YES	BMS overcurrent alarm (effective after successful BMS communication).
63	BMSUnderVolt	NO	BMS undervoltage alarm (effective after successful BMS communication).

8.2 Troubleshooting

Fault Code	Meaning	Causes	Remedy
/	No screen display	No power input, or the switch on the bottom of the unit is not switched on.	Check whether the battery air circuit-breaker or PV air circuit-breaker is turned on. Check if the switch is "ON". Press any button on the screen to exit the screen sleep mode.
01	Battery undervoltage protection	The battery voltage is lower than the value set in 【Battery Setup】 - 【Battery Discharge】 - 【Batt. Under volt. alarm】 .	Charge the battery and wait until the battery voltage is 2V higher than the value set in 【Battery Setup】 - 【Battery Discharge】 - 【Battery Under volt. alarm】 .
03	Battery not connected	Battery not connected or BMS in discharge protection mode	Check that the battery connection is secure. Check that the battery circuit breaker is not tripped. Ensure that the BMS is communicating properly.
04	Battery over-discharge protection voltage	The battery voltage is lower than the value set in 【Battery Setup】 - 【Battery Discharge】 - 【Batt. voltage low fault】 .	Manual reset: Turn off and restart. Automatic reset: Charge the battery so that the battery voltage is higher than the voltage set in the parameter item 【Battery Setup】 - 【Battery Discharge】 - 【Battery Recovery Voltage】 .
06	Battery overvoltage during charging	Battery is in over-voltage condition.	Manually power off and restart. Check to see if the battery voltage exceeds the limit. If it exceeds, the battery needs to be discharged until the voltage is below the battery over-voltage recovery point.
13	Bypass overload (Software detection)	Bypass output power or output current over-load for a period of time.	Reduce the load power and restart the device. Please refer to item 11 of the protection function for more details.
14	Inverter overload (Software detection)	Inverter output power or output current over-load for a period of time.	
19	PV input heat sink over-temperature (Software detection)	Heat sink of PV input temperature exceeds 90°C for 3s.	Normal charging and discharging is resumed when the temperature of the heat sink cools below the over-temperature recovery temperature.
20	Inverter input heat sink over-temperature (Software detection)	Heat sink of inverter output temperature exceeds 90°C for 3s.	
21	Fan fault	Hardware detects fan failure.	Manually toggle the fan after powering off the machine to check for foreign matter blockage.
26	AC input relay short circuit	Relay for AC input sticking.	Manually turn off and restart the machine, if the fault reappears after restarting, you need to contact the after-sales service to repair the machine.
28	Grid input phase fault	AC input phase does not match AC output phase.	Make sure that the phase of the AC input is the same as the phase of the AC output.

NOTICE

If you encounter product faults that cannot be solved by the methods in the above table, please contact our after-sales service department for technical support and do not disassemble the equipment by yourself.

9. Protection and Maintenance

9.1 Protection Features

No.	Protection Feature	Description
1	PV input current limiting protection	When the charging current or power of the PV array configured exceeds the PV input rated value, the inverter will limit the input power and charge at the rated.
2	PV input over-voltage	If the PV voltage exceeds the maximum value allowed by the hardware, the machine reports a fault and stops PV boosting to output a sinusoidal AC waveform.
3	Anti-reverse charge protection at night	At night, the battery will be prevented from discharging to the PV module because the battery voltage is greater than the PV module voltage.
4	AC input over-voltage protection	When the mains voltage of per phase exceeds 280Vac, the mains charging will be stopped and will switch to inverter output.
5	AC input under-voltage protection	When the mains voltage of per phase falls below 170Vac, the mains charging will be stopped and will switch to inverter output.
6	Battery over-voltage protection	When the battery voltage reaches the over-voltage disconnection voltage point, it will automatically stop the PV and mains charging of the battery to prevent over-charging and damage to the battery.
7	Battery under-voltage protection	When the battery voltage reaches the low-voltage disconnection voltage point, it will automatically stop discharging the battery to prevent the battery from being over-discharged and damaged.
8	Battery over-current protection	When the battery current exceeds the range allowed by hardware, the machine will turn off output and stop discharging the battery.
9	AC output short-circuit protection	When a short-circuit fault occurs at the load, the AC output voltage will be switched off immediately and output again after 1 min. If the output load is still short-circuited after 3 attempts, short-circuit fault of the load must be eliminated first and then manually re-powered in order to restore the normal output.
10	Heat sink over-temperature protection	When the internal temperature of the inverter is too high, the inverter will stop charging and discharging; when the temperature returns to normal, the inverter will resume charging and discharging.
11	Inverter over-load protection	<p>Three-Phase Overload Logic: After overload protection is triggered, the inverter resumes output after 3 minutes. If overload occurs five consecutive times, output is disabled until the inverter is restarted.</p> <p>(101% < Load ≤ 110%): Operates normally. (110% < Load < 120%): Alarm triggered; output shuts down after 400–600 seconds. (120% ≤ Load < 130%): Alarm triggered; output shuts down after 200–400 seconds. (130% ≤ Load < 140%): Alarm triggered; output shuts down after 20–200 seconds. (140% ≤ Load < 160%): Alarm triggered; output shuts down after 5–20 seconds.</p> <p>Single-Phase Overload Logic: (140% ≤ Load < 160%): Alarm triggered; output shuts down after 5–20 seconds.</p>
12	AC output reverse	Prevents backfeeding of battery inverter AC to bypass AC inputs.
13	Bypass over-current protection	Built-in AC input overcurrent protection circuit breaker.
14	Bypass phase inconsistency protection	When the phase of the two bypass inputs is different from the phase of the inverter phase split, the machine will prohibit cutting into the bypass to prevent the load from dropping out or short-circuiting when cutting into the bypass.
15	Arc fault circuit interrupter protection (AFCI)	Its primary function is to detect whether electric arcs occur in the wires between the PV modules and the inverter, as well as between PV modules themselves, due to aging or other factors. This protection mechanism prevents fire hazards caused by electric arcs; once an arc is detected, the inverter will immediately shut down its operation to activate protective measures.

16	Anti-Islanding protection	It serves as a safety switch for the power system. When the grid suffers a sudden power outage, it will quickly disconnect the inverter from the grid, preventing the formation of an island and ensuring the safety of maintenance personnel as well as the normal operation of the equipment.
----	---------------------------	---

9.2 Maintenance

To maintain optimum long-lasting working performance, it is recommended that the following items be checked twice a year.

1. Ensure that the airflow around the inverter is not blocked and remove any dirt or debris from the radiator.
2. Check that all exposed conductors are not damaged by sunlight, friction with other surrounding objects, dry rot, insect or rodent damage, etc. The conductors need to be repaired or replaced if necessary.
3. Verify that the indications and displays are consistent with the operation of the equipment, note any faults or incorrect displays and take corrective action if necessary.
4. Check all terminals for signs of corrosion, insulation damage, high temperatures or burning/discolouration and tighten terminal screws.
5. Check for dirt, nesting insects and corrosion, clean as required, clean insect screens regularly.
6. If the lightning arrester has failed, replace the failed arrester in time to prevent lightning damage to the inverter or other equipment of the user.

DANGER

Make sure that the inverter is disconnected from all power sources and that the capacitors are fully discharged before carrying out any checks or operations to avoid the risk of electric shock.

The Company shall not be liable for damage caused by :

1. Damage caused by improper use or use in a wrong location.
2. PV modules with an open-circuit voltage exceeding the maximum permissible voltage.
3. Damage caused by the operating temperature exceeding the restricted operating temperature range.
4. Dismantling and repair of the inverter by unauthorised persons.
5. Damage caused by force majeure: damage during transport or handling of the inverter.

9.3 Storage

If the inverter is not to be put into use immediately, the following requirements shall be met for storage:

- Do not remove the original packaging of the inverter.
- The storage temperature shall be maintained at $-40^{\circ}\text{C} \sim +70^{\circ}\text{C}$; the relative humidity shall be maintained at 5% RH \sim 95% RH.
- Store in a clean and dry place to protect against dust and moisture erosion.
- Maximum stacking height: 4 layers. When stacking, place the inverters with care to prevent tipping over, which may cause personal injury or equipment damage.
- Conduct regular inspections during storage (recommended once every three months). Replace the packaging materials in a timely manner if moth damage, rat bites or packaging damage is found.
- If the storage period is 2 years or longer, the inverter must be inspected and tested by professional personnel before being put into use.

10. Datasheet

Models	IESP500SPH3	IESP500SH3	IESP550SH3	IESP600SH3	Adjustable
Inverter Output (Load)					
Rated Output Power	49990W	50000W	55000W	60000W	
Peak Power (Off-grid)	1.6 times of rated power, 10s			1.5 times of rated power, 10s	
Rated Output Voltage	220/380Vac, 230/400Vac (3L+N+PE)				√
Output Voltage Error	± 5%				
Load Motor Capacity	21HP	21HP	23HP	25HP	
Rated Frequency	50/60Hz ± 0.3Hz				√
Waveform	Pure sine wave				
Switch Time	10ms (Typical)				
AC Output (On-grid)					
Rated Output Power	49990W	50000W	55000W	60000W	
Max. Apparent Power	49990VA	60000VA	60500VA	66000VA	
Power Factor	0.8 leading to 0.8 lagging				
Rated AC Voltage	220/380Vac , 230/400Vac , 3L/N/PE				
Rated AC Frequency	50/60Hz				
Rated AC Current	72.2Aac	72.2Aac	79.4Aac	86.6Aac	
Max. AC Input/Output Current	72.2Aac	86.6Aac	87.4Aac	95.3Aac	
THD	<3% (Rated Power)				
Battery Data					
Battery Type	Lithium-ion Battery				√
Number of Battery Input	2				
Battery Voltage Range	150-820Vdc				
Max. Charging/ Discharging Current	160A(80A+80A)				√
PV Input					
No. of MPPT Trackers	4				
Max. PV Access Power	100kW	100kW	110kW	120kW	
Max. PV Input Power	90000W	90000W	90000W	96000W	
Max. PV Input Current	40A*4				
Max. Short-circuit Current	60A*4				
Start-up Voltage	160V				
Max. Open-circuit Voltage	1000V				
MPPT Operating Voltage Range	150V ~ 850V				

Grid/Generator Input		
Input Voltage Range	0.85Un-1.1Un	
Input Frequency Range	50/60Hz	
Bypass Overload Current	200A	
Efficiency		
MPPT Tracking Efficiency	> 99%	
Max. Efficiency	98.1%	
European Efficiency	97.6%	
Protections		
PV Input Lightning Protection	Yes	
Anti-islanding Protection	Yes	
PV String Input Reverse Polarity Protection	Yes	
Insulation Resistor Detection	Yes	
Residual Current Monitoring Unit	Yes	
Output Over Current Protection	Yes	
Output Shorted Protection	Yes	
Surge Protection	DC type II/AC type II	
Overvoltage Category	DC type II/AC type III	
Certification		
On-grid Standard	EN50549,VDE4105	
Safety	IEC62109-1, IEC62109-2	
EMC	EN61000-6-1, EN61000-6-3, FCC 15 class B	
RoHS	Yes	
General Data		
Parallel Capacity	1-9 Units	
Operating Temperature	-40~60°C, >45°C derated	
Humidity Range	0 ~ 100% RH	
Noise	<65dB	
Protection Degree	IP65	
Cooling Method	Heat sink + intelligent air cooling	
Standby Power Consumption	<30W	
Dimensions	622x342x1010mm	
Weight	98kg	
Communication Interface	RS485 / CAN / USB /Dry contact	√
External Modules	Wi-Fi / 4G Stick (Optional)	√



SRNE Solar Co.,Ltd

Mail	master@szshuori.com
------	---------------------

Web	www.srnesolar.com
-----	-------------------

Address	4-5F,Building13A,Taihua Wutong Industrial Park ,Gushu Development Zone , Hangcheng Street,Baoan, Shenzhen, China PR
---------	---

